

REVISION				
REV	DESCRIPTION	ECN	DATE	BY
01				

- GENERAL NOTES:**
(UNLESS NOTED OTHERWISE)
- ALL DIMENSIONS SUBJECT TO CHANGE WITHOUT NOTICE.
 - FOR STEP FILE SEE: 213-00000-000_STEP

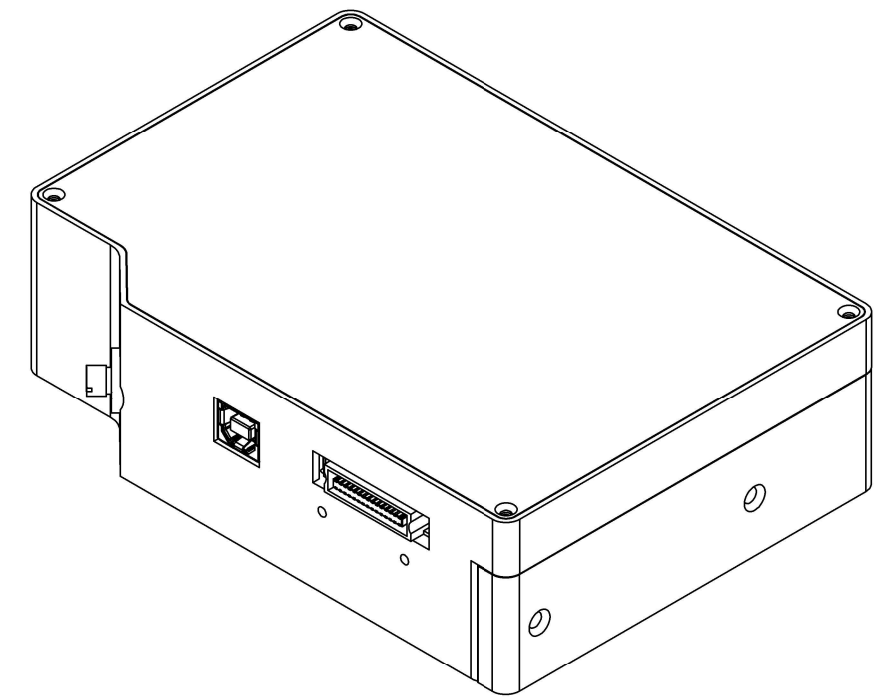

<p>3500 Quadrangle Blvd. Orlando, FL 32817</p> <p>727 733 2447 www.oceaninsight.com</p> <p>PROPRIETARY AND CONFIDENTIAL</p> <p>THE INFORMATION CONTAINED IN THIS DRAWING IS THE SOLE PROPERTY OF OCEAN INSIGHT, INC.</p> <p>ANY REPRODUCTION IN PART OR AS A WHOLE WITHOUT THE WRITTEN PERMISSION OF OCEAN INSIGHT, INC. IS STRICTLY PROHIBITED.</p> <p>DO NOT SCALE DRAWING</p>	<p>- DIMENSIONS IN INCHES - UNLESS OTHERWISE NOTED</p> <p>.XX ±.01</p> <p>.XXX ±.005</p> <p>.XXXX ±.0005</p> <p>Angular ±0.5°</p>	<p>DATE</p> <p>MODELED 12/04/2015</p> <p>DRAWN 12/04/2015</p>	<p>NAME</p> <p>R. BROSILOW</p> <p>R. BROSILOW</p>	<p>TITLE:</p> <p>HR PRO SPECTROMETER ASSEMBLY</p>	
	<p>THIRD ANGLE PROJECTION</p>	<p>INTERPRET GEOMETRIC TOLERANCING PER: ASME Y14.5-2009</p>	<p>COMMENTS:</p>	<p>PART NO.</p> <p>213-00000-000</p>	<p>SIZE</p> <p>B</p>
	<p>MATERIAL</p>	<p>FINISH</p>	<p>SCALE: N/A</p>	<p>DWG. NO.</p> <p>213-00000-000_CD</p>	<p>REV</p> <p>01</p>
	<p>DO NOT SCALE DRAWING</p>	<p>SHEET 1 OF 1</p>	<p>DATE</p>	<p>NAME</p>	<p>TITLE:</p>