



SpeedSorter™

System Manual – Revision 4 (2022-10-24)

Locations

Americas

Manufacturing & Logistics

3500 Quadrangle Blvd., Orlando, FL 32817, USA

Sales: info@oceaninsight.com

Orders: orders@oceaninsight.com

Support: techsupport@oceaninsight.com

Phone: +1 727.733.2447

Fax: +1 727.733.3962

Ocean Insight Rochester, NY

176 Anderson Ave, STE 304, Rochester, NY 14617

International Light Technologies, Inc.

10 Technology Drive, Peabody, MA 01960

Europe, Middle East & Africa

Sales & Support

Geograaf 24, 6921 EW Duiven, The Netherlands

Manufacturing & Logistics

Maybaachstrasse 11, 73760 Ostfildern, Germany

Email: info@oceaninsight.eu

Netherlands: +31 26-319-0500

Netherlands Fax: +31 26-319-0505

Germany: +49 711-341696-0

UK: +44 1865-819922

France: +33 442-386-588

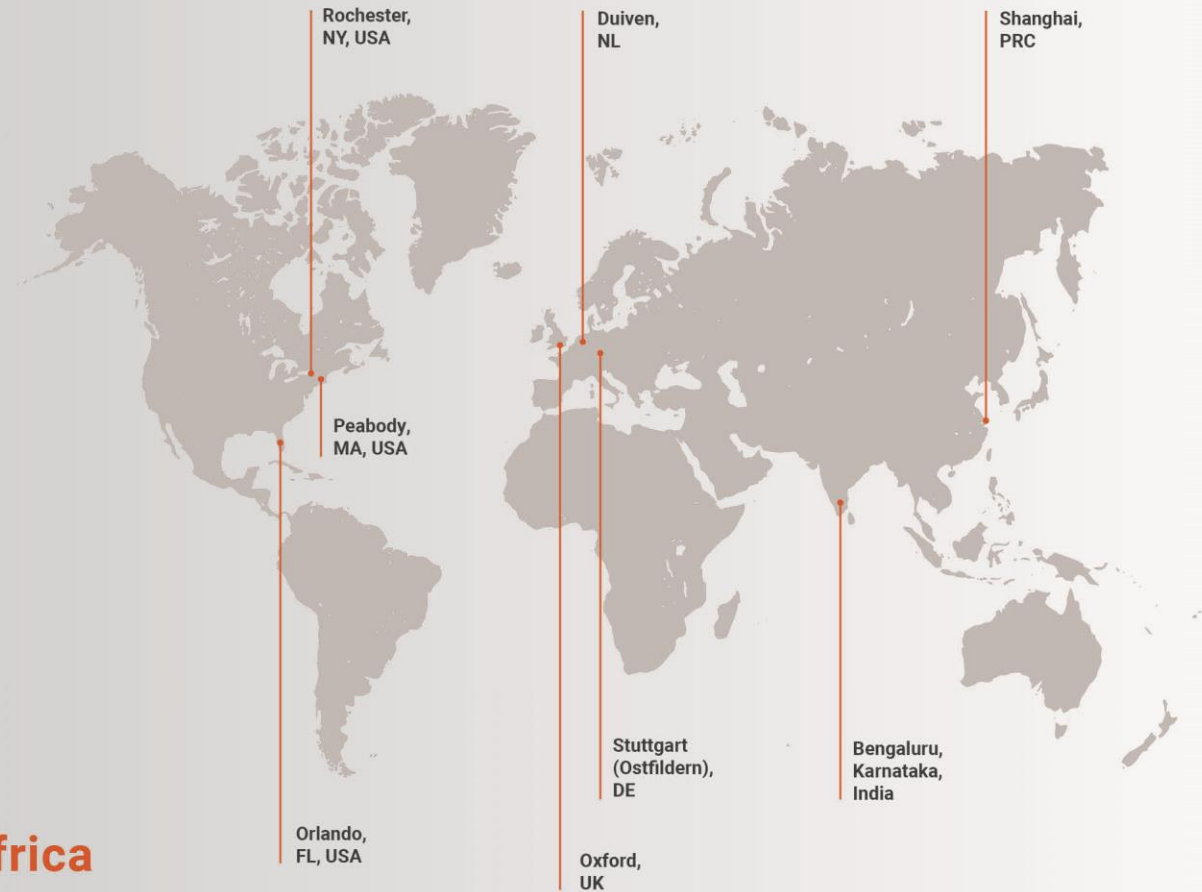

Asia

Ocean Insight China

666 Gubei Rd., Kirin Tower Suite 601B
Changning District, Shanghai, PRC, 200336

Email: asiasales@oceaninsight.com

China: +86 21-6295-6600

China Fax: +86 21-6295-6708

Japan & Korea: +82 10-8514-3797

Ocean Insight India

Prestige Shantiniketan, Gate no.2
Tower C, 7th Floor
Whitefield main road, Mahadevpura
Bengaluru-560048 Karnataka, India

Phone: +91 80-67475336

Table of Contents

About This Manual.....	1
Warnings and Cautions	1
Optical Safety	1
Warranty	2
Product-Related Documentation	2
Introduction.....	1
Theory of Operations.....	1
System Workflow	2
System Layout	3
Electrical Specifications.....	5
Power Supply	5
SpeedSorter Rear Panel	5
Power Button.....	6
Coaxial Connector	6
External Coaxial Cable.....	7
Power Connector	7
External Power Cable	8
Ethernet Port	8
External Ethernet Cable	8
System Specifications.....	9
Installation and Alignment	10
Laser Area Enclosure.....	11
Eye Protection	12
Preventive Maintenance.....	12

Using the SpeedSorter	14
Connecting to the SpeedSorter.....	14
SpeedSorter CONSOLE Software.....	15
Overview.....	15
Configuring network adapter settings	16
Using the SpeedSorter CONSOLE Application. 18	
Initial Setup	19
Changing User Level Modes	20
User Interface Layout	21
Technician Mode.....	22
Creating a Recipe	27
Single Threshold	27
Min-Max	28
Logic String.....	29
Setting Divert Parameters	30
Loading a Recipe.....	31
Viewing and Understanding Data	32
Saving Data.....	33
Additional Features for Technicians.....	34
Spectrum Graph	34
Operator Mode	35
Running the Lasers/Begin Sorting	38
Software API Layer Overview	39
Client-Server Architecture	39
Application Protocol	39

Message Types Request from Client	41
System Information	41
System Environmental Condition	41
Data Acquisition.....	41
Laser Control.....	43
Divert Control	44
Response from server	45
System Information	45
System Environmental Condition	45
Data Acquisition.....	46
Laser Control.....	48

Divert control	49
Other.....	49
UDP Data Reporting Protocol	50
Definitions of Terms	53
Keep Alive message	53
Analysis modes.....	53
Single Threshold	53
Min - Max	53
Logic String.....	53
Divert parameters	54
Result Code	54

Copyright © 2022 Ocean Insight

All rights reserved. No part of this publication may be reproduced, stored in a retrieval system, or transmitted, by any means, electronic, mechanical, photocopying, recording, or otherwise, without written permission from Ocean Insight.

This manual is sold as part of an order and subject to the condition that it shall not, by way of trade or otherwise, be lent, re-sold, hired out or otherwise circulated without the prior consent of Ocean Insight, Inc. in any form of binding or cover other than that in which it is published.

Trademarks

All products and services herein are the trademarks, service marks, registered trademarks or registered service marks of their respective owners.

Limit of Liability

Every effort has been made to make this manual as complete and as accurate as possible, but no warranty or fitness is implied. The information provided is on an “as is” basis. Ocean Insight shall have neither liability nor responsibility to any person or entity with respect to any loss or damages arising from the information contained in this manual.

About This Manual

Warnings and Cautions



Warning

This device contains no user-serviceable internal parts. Opening the case and improper use can result in injury, blindness, death, or damage to property, including the instrument itself. This instrument should only be operated after proper training and instruction.

Even the simple maintenance described in this manual must be performed by trained personnel. The instrument must be returned to Ocean Insight for repair.

Optical Safety

Caution: The principal hazard associated with this laser is direct and reflected ocular exposure. Users who may be exposed to this laser during alignment exercises should wear suitable safety glasses.

Caution: Blindness and burns can result in the case of exposure to both direct and reflected beams. The use of safety glasses is necessary whenever any portal in the material delivery system is open.

Caution: This device is designed to be an OEM component and does not meet the requirements for a stand-alone laser system. The integrator is responsible for the provision of a system that meets all local requirements to maintain safety. This may include extensive interlocking, key access, a housing structure that protects the user and any bystanders, and indicators of active emission. This list may not be complete.

Caution: THE INSTRUMENT MUST NEVER BE OPERATED OUTSIDE OF THE DELIVERY SYSTEM UNDER ANY CIRCUMSTANCES.

Caution: IT IS THE INTEGRATOR'S RESPONSIBILITY TO CREATE A COMPLETE SYSTEM COMPLIANT WITH REGULATORY REQUIREMENTS.

Caution: OI ASSUMES NO LEGAL RESPONSIBILITY ASSOCIATED WITH THE USE OF THIS DEVICE.

Warranty

For the most current warranty information, please refer to your purchase order and/or contract associated with the order.

Product-Related Documentation

Contact your local sales representative or appliedsystems@oceaninsight.com for more information, such as digital copies of manuals, CAD files, etc.

Introduction

Theory of Operations

SpeedSorter is an advanced spectroscopic device designed for the high-speed detection and separation of metallic alloys.

Using Laser-Induced Breakdown Spectroscopy (LIBS), the SpeedSorter focuses a high-powered laser beam onto the surface of a moving piece of scrap metal. A unique spectral “fingerprint” is identified from the plasma, where the appearance and intensity of certain wavelengths are proportional to the presence and relative concentration of alloying elements to those of a sample’s base element.

Using these ratios of “alloying element wavelength intensity” to “base element wavelength intensity”, the software can setup process control thresholds (or recipes) to sort one type of sample that meets the separation criteria, from those parts that fail those same criteria.

This analysis is performed at an incredibly high rate of speed and accuracy, making the device ideal for sorting scrap metal.

Typical scrap metal sorts can be the following:

- Wrought alloys from cast alloys
- 5xxx aluminium from 6xxx aluminium
- 6063 aluminium extracted from mixed 6xxx scrap
- Extracting aluminium from scrap with copper, iron, or zinc-based alloys
- Many other types of sorts possible, only limited by the level of detection limits for a given element and how close one alloy’s elemental composition specification is to that of another.

System Workflow

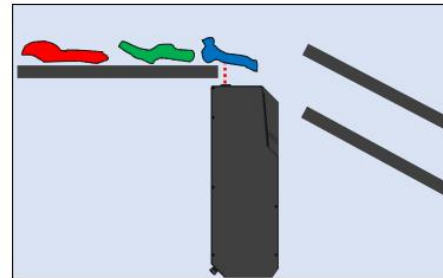

Simplified part processing block diagram sequence

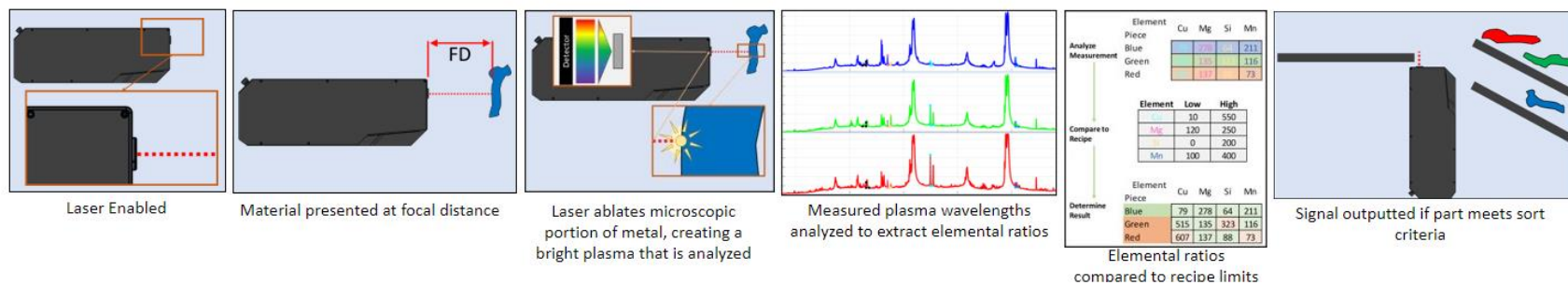

Figure 1: Workflow Diagram

A visual representation of the system's operation is shown above, but the general principles are the following:

1. The SpeedSorter is to be mounted in a fixed position, inside a laser-safe enclosure that fully shields nearby people from any glancing angle or reflection from the laser beam, including when it may reflect randomly off of a scrap sample.
2. The laser and material handling system are enabled. The material handling system feeds scrap samples in a singulated manner. Assuming a part speed of 2.5m/s, the parts should be separated by at least 30mm. Adjusting material feed rate will require adjustment in minimum distance between parts. It is critical that a portion of the parts' surface passes through the laser's focal point of 250mm.
3. The laser ablates a small portion of the metal which produces a plasma that emits light.
4. The spectrometer analyzes the light collected from the plasma and the software determines if the part meets or does not meet thresholds that correspond to the type of desired metal sort.
5. The system sends out of a pulse to a customer's diverter mechanism to physically move the part to a desired material stream.

System Layout

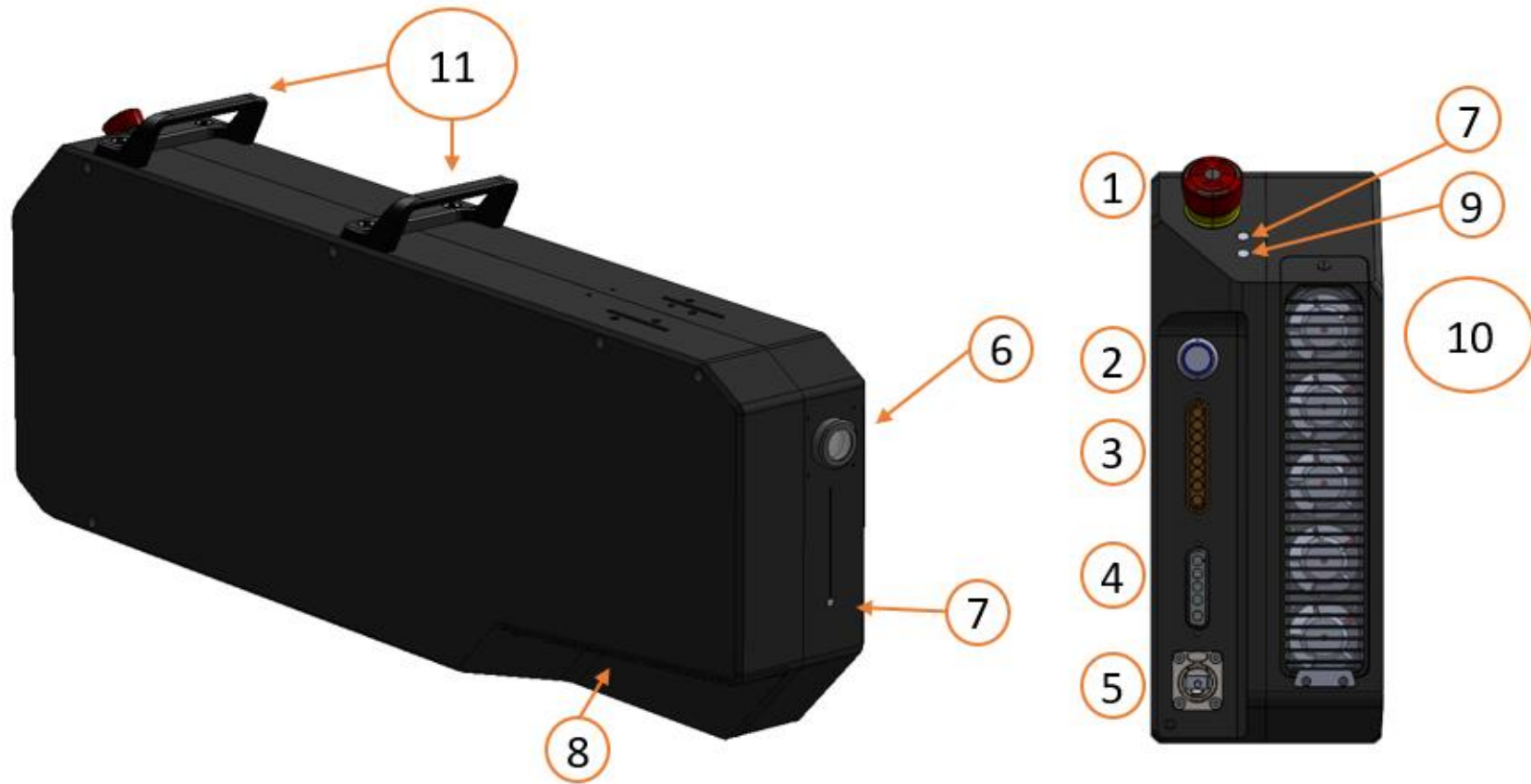

Figure 2: System Layout

ID	Component	Description
1	Emergency Stop	Pressing this button immediately disables the laser. It does not disable system power. Twist the Emergency Stop button clockwise to allow the laser to be re-enabled by software control.
2	Power Switch	Pressing this button turns the system on/off. The button illuminates blue when the system is on.
3	Coaxial I/O	This 8-pin D-Sub connector contains all I/O (e.g., laser-on signal, remote interlock control). A 3-meter coaxial cable is provided with the desired signals. The connector's backshell must be securely tightened upon install.
4	Power Input	This 5-pin D-Sub connector accepts the 24 VDC input power. A 3-meter power cable is provided. The connector's backshell must be securely tightened upon install.
5	Ethernet Port	Provides control and data access to the system. A 30-foot Cat 6 Ethernet cable is provided.
6	Protective Window	The laser energy emits through this replaceable glass window. This is required to be cleaned when dirty or replaced if damaged.
7	Laser On Indicator LED	Unilluminated: Laser is off Illuminated Red: The IR laser is firing There is one LED located on the front face of the instrument, and one duplicate LED on the top-rear panel.
8	Exhaust Fans	There are four fans which push air out of the system, located on a recessed area along the bottom of the instrument. A protective finger guard is placed over these fans.
9	Operational Status Indicator LED	Unilluminated: The internal computer has not fully started. This is normal immediately after power-on Green: The instrument is fully powered on and the internal computer has successfully started. The unit is idle and waiting for an external Ethernet connection from a client PC, PLC, etc. Blue: The instrument has detected an active Ethernet connection to an external device
10	Intake Fans & Filter	There are five fans which pull air into the system. A replaceable 80 PPI filtering mesh is required under the finger guard after removing a retaining thumb screw. A replacement filter is provided in addition to the pre-installed filter. Filters may be cleaned by running water through them from the less-dirty side, squeezing, and allowing them to dry. New filters may be cut from McMaster-Carr, 9803K91.
11	Transportation Handles	These handles help the system to be carried but may be removed when desired.

Electrical Specifications

Power Supply

Standard Power Supply

The SpeedSorter requires a power supply capable of providing 600W of sustained power at 24VDC. A power supply is included with the instrument.

3 - Unit Power Supply

A power supply capable of supplying power to 3 units simultaneously is available as an option. Contact Ocean Insight for more details.

SpeedSorter Rear Panel

VIEWED ON SPEEDSORTER

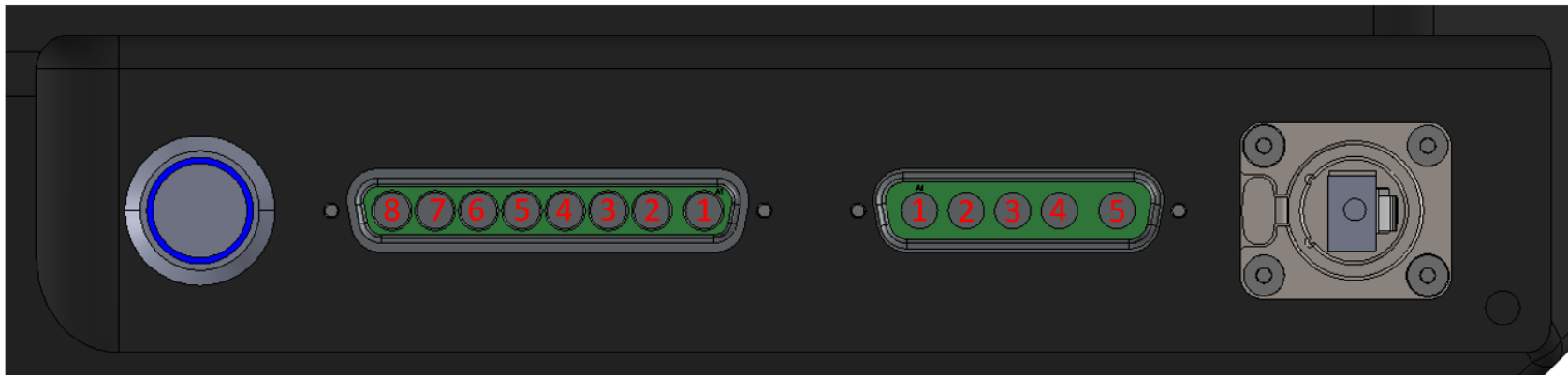

Figure 3: SpeedSorter Rear Panel

Power Button

Press the power button to start the system. The blue ring will illuminate indicating power is on, and the fans will begin running, which is audible.

Coaxial Connector

Pin	Description	Input/Output	Details
1	Divert	Output	24VDC output, rising edge The delay from piece detection, and the pulse duration are configurable in software
2	Laser On	Output	24VDC output when laser is emitting
3	Safety Interlock	Input	Close circuit to enable laser emission. Laser cannot emit when circuit is open.
4	Sync In	Input	Reserved for future use
5	Fan On	Output	24VDC output. Indicates system cooling fans are enabled and end-user cooling system should be running. If Fan On signal is off while the unit is turned on, this indicates the unit is self-heating and is detecting a cold ambient condition (under 5°C) and end-user cooling system should be temporarily deactivated to help the SpeedSorter reach its nominal operating temperature (5-40°C).
6	N/C	--	--
7	N/C	--	--
8	N/C	--	--

External Coaxial Cable

A custom 8-position coaxial cable is provided that interfaces to the rear panel of the SpeedSorter.

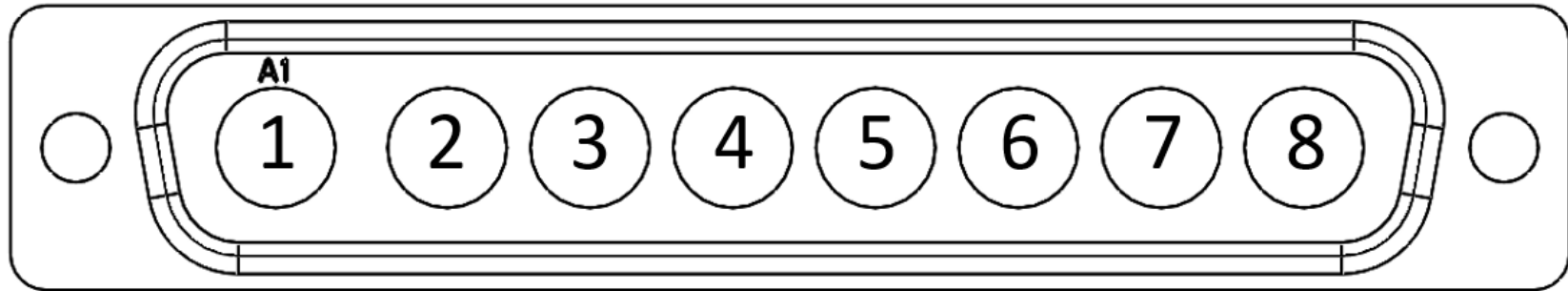

Figure 4: Coaxial Cable Pinout, viewed from end of cable

Power Connector

Pin	Description	Details
1	+24VDC	24VDC Rail 1
2	+24VDC	24VDC Rail 2
3	Earth Ground	Ground to verified earth ground location
4	GND	Ground
5	GND	Ground

External Power Cable

A custom power cable is supplied with the system.

Note: Only use the cable supplied by Ocean Insight.

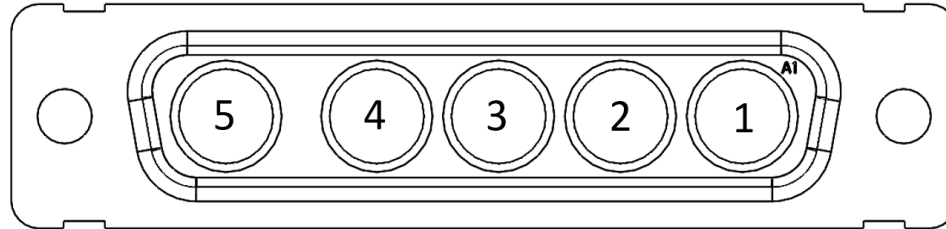

Figure 5: View from visible end of power cable

Ethernet Port

The system communicates to a client PC or PLC via Ethernet cable.

External Ethernet Cable

A 30ft Cat 6 Ethernet cable is provided. If a different length is desired, you may source any shielded Cat 6 Ethernet cable.

System Specifications

Dimensions	860mm x 300mm x 120mm	(33.8" x 11.8" x 4.7")
Weight	27kg	(60lb)
Operational Temperature	0-40°C	(32-104°F)
Non-Operational (Storage) Temperature	-10-50°C	(14-122°F)
Relative Humidity	5-85% (non-condensing)	
Ingress Protection	Not IP Rated	
Air Filtering	<5 micron, non-conductive particulates	

Note: End-user must supply adequate cooling air at approximately 150 CFM to SpeedSorter to ensure proper cooling. Actual environmental conditions may require higher flow, air-conditioned flow, and air containing particulates less than 5 microns in size.

SpeedSorter contains a user-replaceable air filter which must be cleaned or replaced depending on environmental conditions. Elevated system temperatures reported in the software GUI can indicate an air flow restriction or clogged filter.

Note: Due to dust or particulates present in a typical operating environment, it is required to install a pressurized air device that keeps particulates away from the laser output window. Each installation is unique, and Ocean Insight can provide recommendations on how to implement such a device. Typically, 100 CFM per module should be budgeted for this airflow device.

Installation and Alignment

The SpeedSorter is built with a variety of mounting holes to allow mounting from the top or bottom of the instrument.

The carry handles are removable.

The most important aspect of mounting the instrument is ensuring the 250mm focal distance of the laser is positioned such that the focal point contacts the surface of the metal object being measured.

Typically, useable signal can be obtained within a 250 +/- 5mm tolerance range, but the most powerful plasma reaction occurs at 250mm and results in the most accurate and reliable measurement. It also helps with ablating through light dust, dirt, paint, or other contaminants.

As parts move too close or too far away, the plasma will become weak, or non-existent, and a measurement will not be possible.

The material handling system must also ensure the parts are presented to the instrument in a dynamic, moving way. A part speed of approximately 2.5-3.0m/s is recommended, but not a strict requirement. Slower than this can result in a weak plasma, and too fast may not allow the system to acquire enough spectra on a part as it moves through the detection region.

Note: A CAD model will be provided upon request to assist with designing mounting hardware and systems integration work. E-mail appliedsystems@oceaninsight.com for more information.

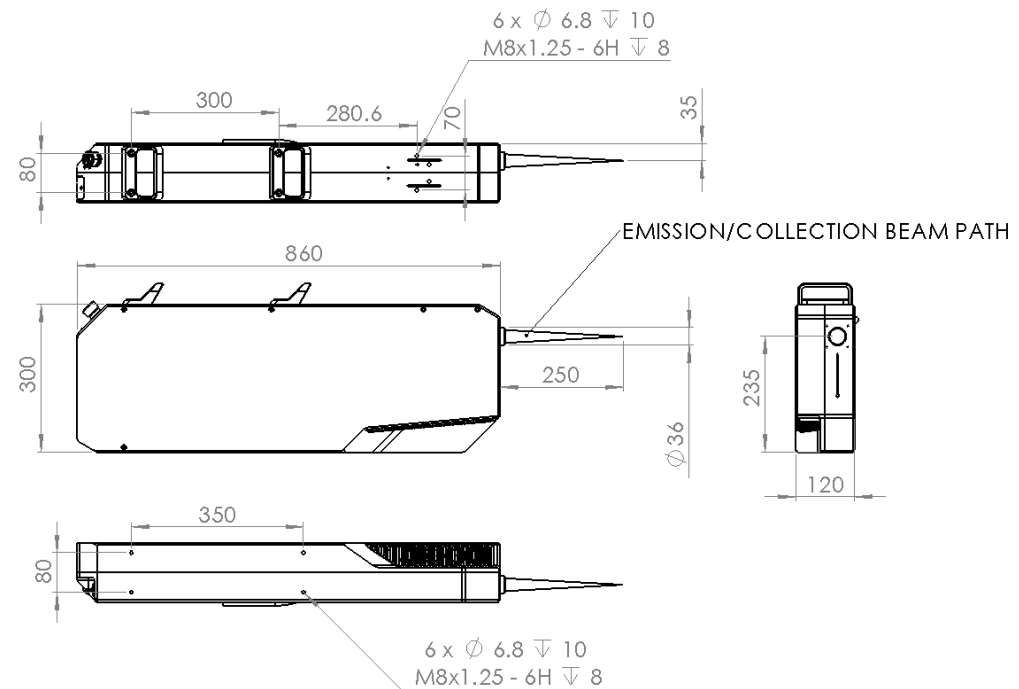

Figure 6: System Dimensions

Laser Area Enclosure



SpeedSorter uses a high-powered laser, which is inherently dangerous. The light is 1064nm (infrared) and invisible to the human eye. This makes it especially dangerous as your eye cannot react and blink during an accidental exposure, which greatly increases the risk of eye damage from both direct or indirect exposure.

Additionally, the laser is high power and can burn through objects. The SpeedSorter must be placed in an interlocked and metal-shielded enclosure to ensure no stray light be exposed to a person nearby.

The beam must also be pointed into a dissipating beam dump placed at least 500mm from the face of the instrument (e.g. 2 focal lengths). The recommended beam dump is the Thorlabs LB2/M and can be purchased here:

<https://www.thorlabs.com/thorproduct.cfm?partnumber=LB2/M>

The beam dump ensures that the laser energy is absorbed and does not reflect in unwanted directions, and also has a built-in heatsink to dissipate the heat. Cooling fans are not required; however, the beam dump should be mounted to something metal to further help with heat transfer because the beam dump will become very hot.

Note: Enable the visible red laser pilot light to visually confirm the red beam is fully contained within the beam dump's diffuse inner surface before use. This is an eye-safe alignment beam.

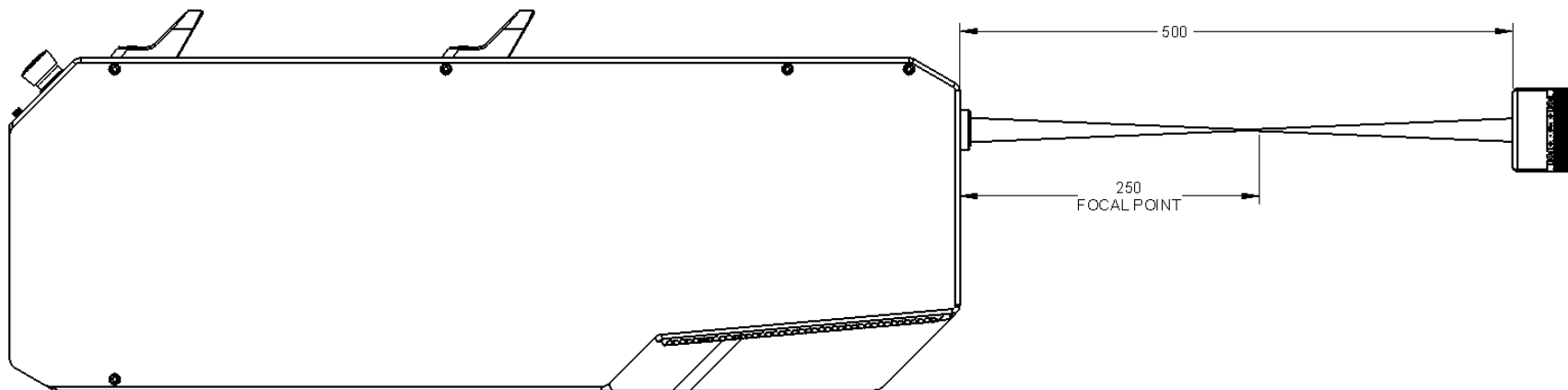

Figure 7: Recommended Beam Dump Placement

Eye Protection



Whenever working near the laser while it is running, you must wear protective eyewear. These laser glasses are recommended to protect from stray reflections. They are specially designed to protect against stray reflections of the 1064nm laser light and are rated for Optical Density (OD) 7+ at that wavelength.

<https://www.thorlabs.com/thorproduct.cfm?partnumber=LG1C>

Note: Even with glasses, never place your head, face, or body anywhere near the laser. Exercise extreme caution at all times.

Preventive Maintenance

Protective Window Assembly

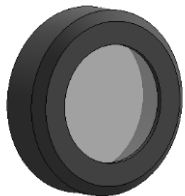

It is extremely important that the front window is kept clean. It is recommended to install one or more pressurized air baffles that provide positive air pressure to keep small particulate debris from collecting on or near the window. A larger physical barrier should also be mounted in a way to prevent any large pieces of debris or infeed material from having any chance to make contact with or damage the window.

Should the window become dirty, ensure the laser is off. Blow off with a can of compressed air to remove larger particulates. Then gently wipe with a lint-free cloth dipped in 90% isopropyl alcohol, then re-wipe with a clean dry lint-free wipe. Blow off again. Repeat as necessary until the window is crystal clear.

If the window is uncleanable or becomes damaged, replace the window assembly with a spare under the guidance or direction of an Ocean Insight service technician.

This should be done in a room far from the sorting machine. Ensure no debris or dust of any kind falls into the optical cavity with the protective window removed. Irreversible damage could occur. Contact Ocean Insight for spare parts.

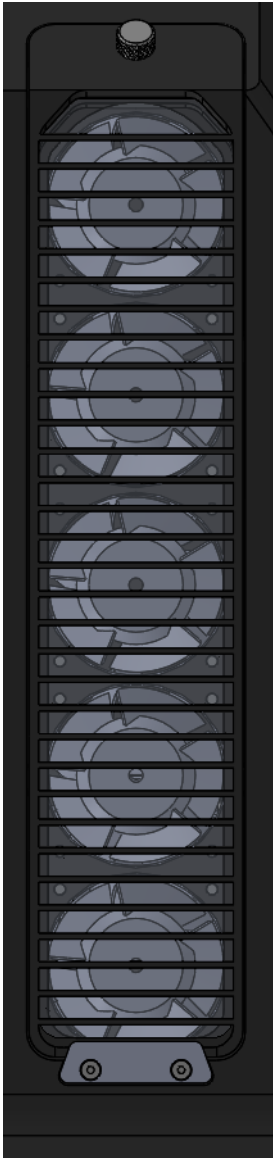

Fan Filter

The fan filter should be replaced whenever the filter media becomes visibly dirty, or when airflow is restricted to the point one can observe internal temperatures reaching a steady-state level higher than normal.

To replace or clean the filter, loosen and remove the thumbscrew and lift the filter holder out.

Gently separate one end of the holder and remove the filter. Rinse it under warm water (from the clean side, flushing out towards the dirty side) then pat dry with a paper towel.

Make sure the filter is completely dry, then reinsert into the filter holder and reinstall in the instrument.

Replacement fan filter material (which needs to be cut to 40mm x 200mm) can be re-purchased here: <https://www.mcmaster.com/9803K91/>

Using the SpeedSorter

Connecting to the SpeedSorter

Before using SpeedSorter, please ensure the following:

1. Verify the power supply and power cable is properly wired. Check the power cable with a voltmeter to confirm.
 - a. **Warning:** Miswiring the power supply and attempting to power the SpeedSorter can result in irreversible damage requiring repair at Ocean Insight.
2. Plug in coaxial I/O
 - a. **Note:** The interlock circuit must be closed in order to fire the laser. This should be done only once the instrument is enclosed and shielded within an eye-safe enclosure that eliminates any possibility of exposure to a human or combustible material.
3. Plug in the Cat 6 Ethernet cable and connect to a Windows 10 PC
4. Press the SpeedSorter's power button. The blue ring should illuminate, and the fans should turn on, producing an audible noise. Briefly the fans may stop, the restart, during initial startup. This is normal.
5. Once the rear status light turns blue, you may connect to the device using SpeedSorter CONSOLE software.

SpeedSorter CONSOLE Software

Overview

SpeedSorter CONSOLE is a desktop PC application designed to communicate with the SpeedSorter, a LIBS-based metal sorting instrument. The SpeedSorter CONSOLE is intended to be run on a computer (“client computer”). This document details the different features of the SpeedSorter CONSOLE application and how to effectively use them to control one or more SpeedSorter modules.

SpeedSorter CONSOLE requires Windows 10 (or later), with a preferred screen resolution of 1920x1080.

You must first configure your network adapter settings described below. Then, to install, copy the SpeedSorter Control program from the flash drive provided to the proper folder and launch the .exe executable.



Figure 8: SpeedSorter CONSOLE GUI

Configuring network adapter settings

By default, the SpeedSorter modules are configured to have a static IP address of 10.1.1.xxx over Ethernet, where xxx is a number between 0 and 255, and corresponds to the serial number of the unit, which can be found on a white label on the top-rear of the instrument near the Emergency Stop button. For example, SpeedSorter SSG2-FS-024 has an IP address of 10.1.1.24.

The client computer needs to be configured to be on the same subnet as the SpeedSorter module. On Windows, the network settings can be configured with the following steps:

1. Access Network and Internet settings via Control Panel (which can be accessed via the Start Menu)
2. Click on "Network and Sharing Center"
3. Select the network adapter/connection that is being used to connect to the SpeedSorter module. This is most likely one of the Ethernet connections.
4. Right-click and select "Properties"

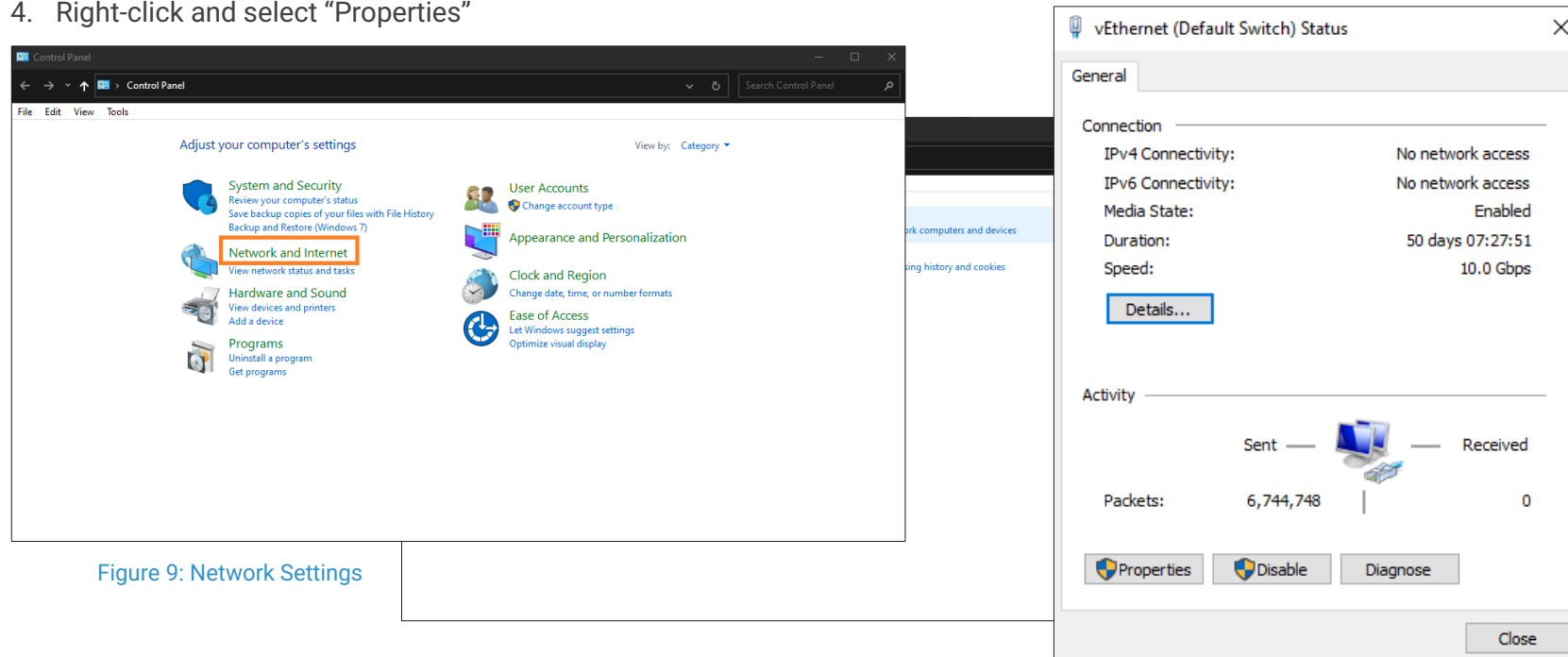

Figure 9: Network Settings

5. Select “Internet Protocol Version 4 (TCP/IPv4) and click “Properties”
6. Change the IP address and DNS settings as shown in Figure 10:
7. Click “OK” to apply the settings

The computer should be able to communicate with the SpeedSorter module now. To check that the client computer can communicate with the SpeedSorter module, a ping test can be performed:

1. In the Windows Start Menu, use either PowerShell or Command Line tool.
2. In PowerShell/Command Line, type the following command: “ping <IP Address of module>”
3. A successful ping test would show that the module replies to the ping sent from the client computer.

Note: You must make sure to specify a static IP address of the client computer different from that of the SpeedSorter module(s) that are hooked up to your local area network or PC.

Note: When using multiple SpeedSorters, it is recommended to have all SpeedSorters route through a single Ethernet switch directly to the client computer Ethernet port. Use of multiple Ethernet switches can cause connection malfunctions if not configured properly.

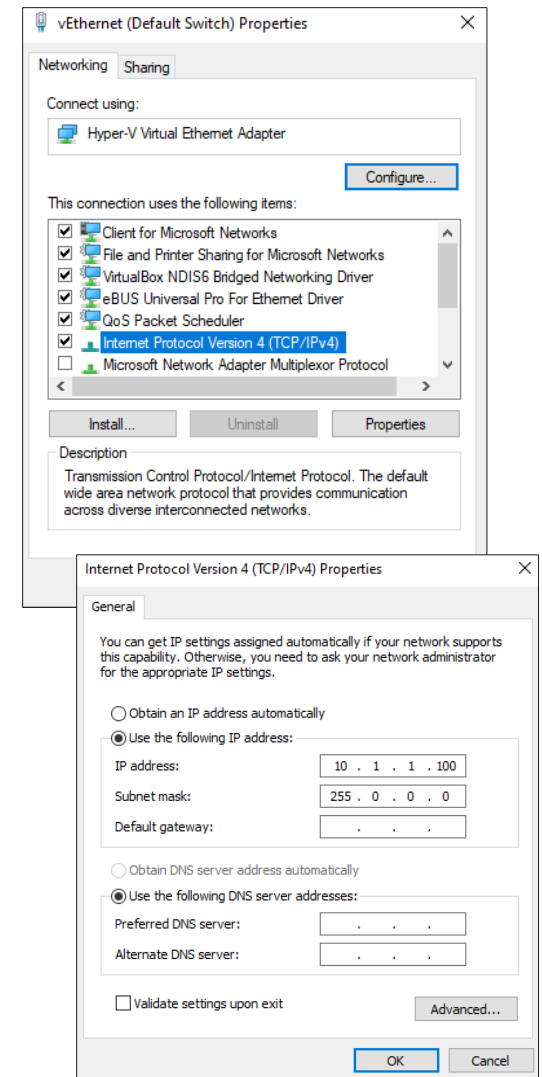

Figure 10: Adapter Configuration

Using the SpeedSorter CONSOLE Application

Upon launching the SpeedSorter CONSOLE.exe executable, a Windows Firewall message may appear. You must click “More Info”, then “Run Anyway” in order for the software to work and open the communication ports within Windows to allow connections to the SpeedSorter device(s).

Note: It is common that firewalls will not always pop up a message automatically to enable the TCP/IP communication. If that occurs and the software does not connect, contact Ocean Insight for assistance.

Depending on other firewall settings or Windows OS versions, other windows may pop up. Accept or allow any dialog box that may appear.

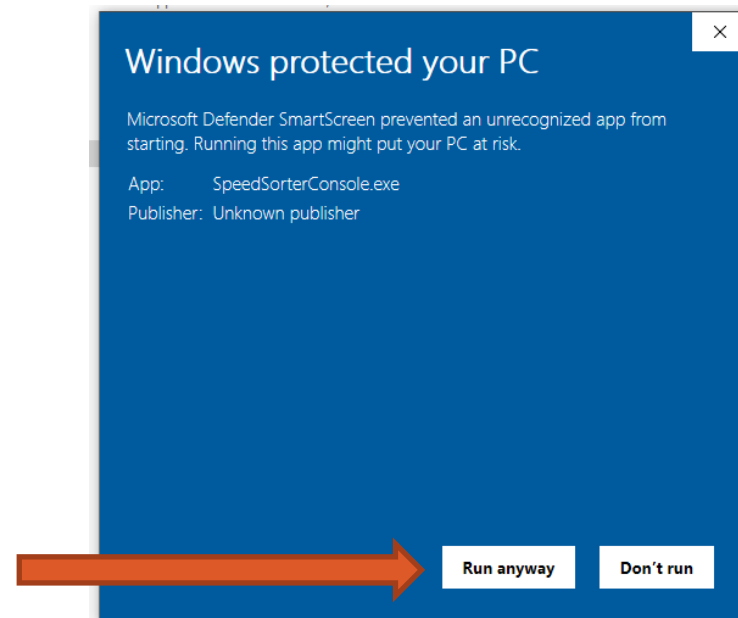
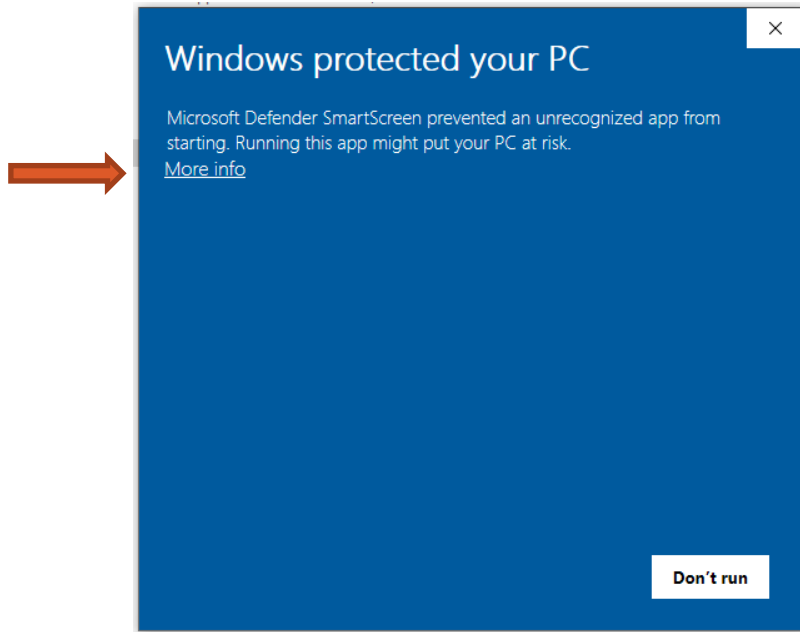

Initial Setup

On startup, the software will begin in **Operator Mode**, which is a function-restricted mode designed for day-to-day use by machine operators.

The SpeedSorter CONSOLE currently supports two user levels:

- **Operator:** the default user level. In this user level, the software will only allow the user to make connections, load recipes, operate the main and pilot lasers, and save data. The user cannot make any changes to the divert logic or parameters.
- **Technician:** In this user level, the software will allow the user more capability to adjust the recipe, divert logic, divert parameters, and analysis mode. Additionally, the spectrum graph will also be shown below the count/ratio graphs.

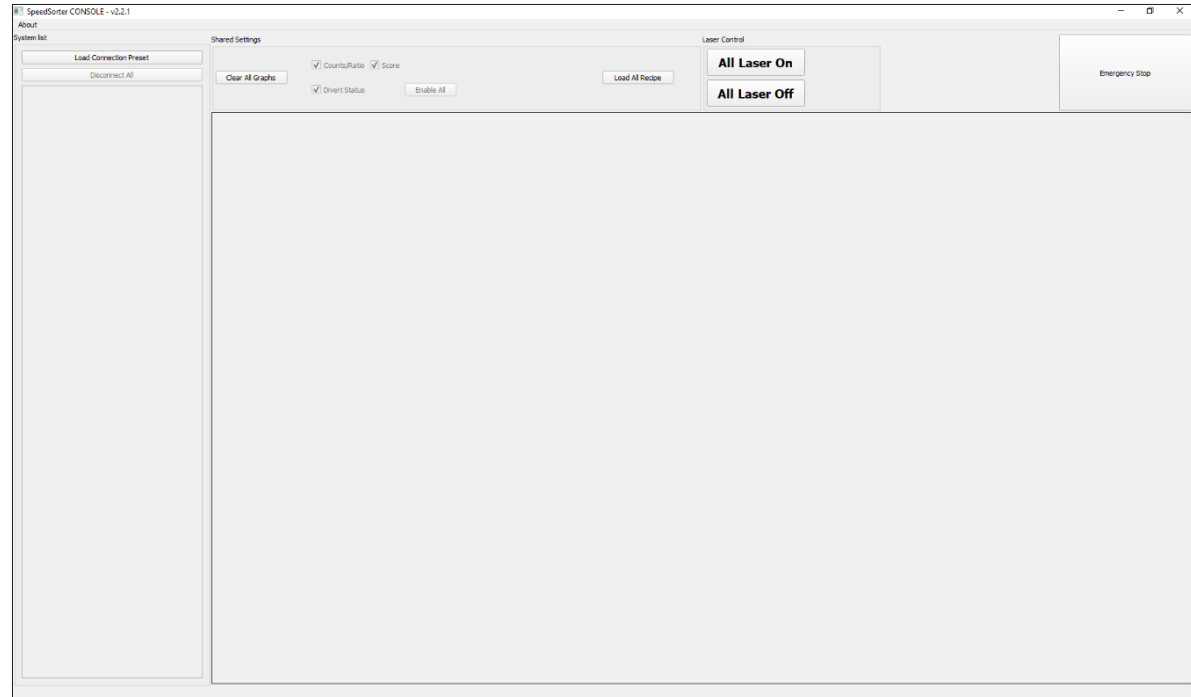

Figure 11: System Startup Window

Changing User Level Modes

To change system parameters, the user must elevate the user level to **Technician Mode**. The user can use the hotkey combo: "Ctrl+U+L", which stands for "User Level".

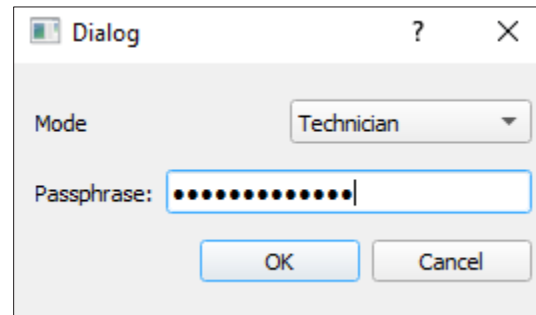

Figure 12: User level selection dialog

A menu will pop up asking the user to select the user level to be switched to. For Operator mode, no passphrase is required. To enable Technician mode, the user will need to enter the passphrase: **coldscientist**

User Interface Layout

The SpeedSorter CONSOLE application is visually divided into four main panels:

- 1. Connection panel** (shaded blue)
This panel contains several input fields to allow the user to specify the network address and ports of a module to be connected to.
- 2. System List panel** (shaded green)
This panel shows a quick summary of all the modules currently being controlled by the SpeedSorter CONSOLE application as well as buttons to allow quick

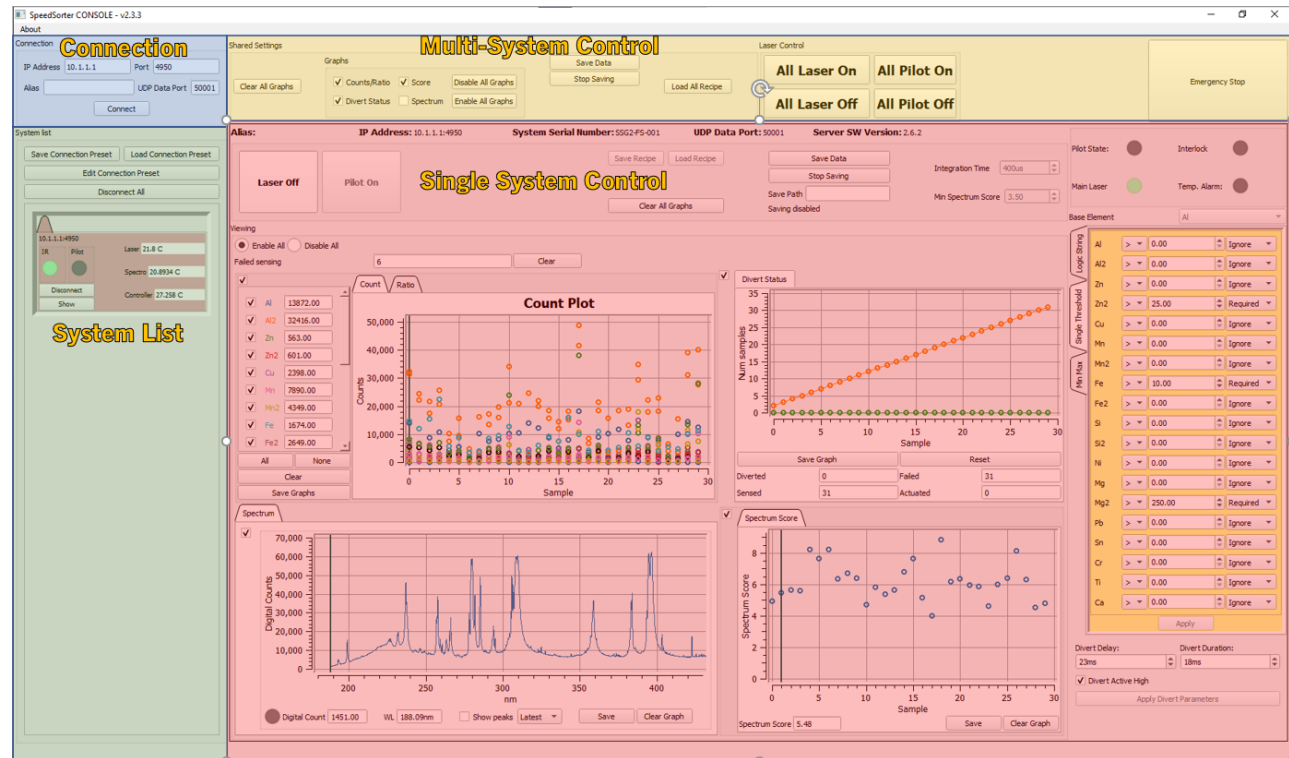

Figure 13: User Interface layout

connection/disconnection to multiple systems. Information regarding analytical laser and pilot laser status, system temperatures, and system-specific IP addresses are viewable.

- 3. Single System Control panel** (shaded red) This panel shows the parameters being used for the currently selected module. It also shows the different plots related to the sorting operation (counts, ratios, divert status, spectrum score) and the status/alarms for the current system.
- 4. Multi-System Control panel** (shaded yellow)
This panel contains several global controls that affect all modules connected to the client software as a group.

Technician Mode

Once Technician mode is enabled, a variety of new functionality becomes enabled, and described below.

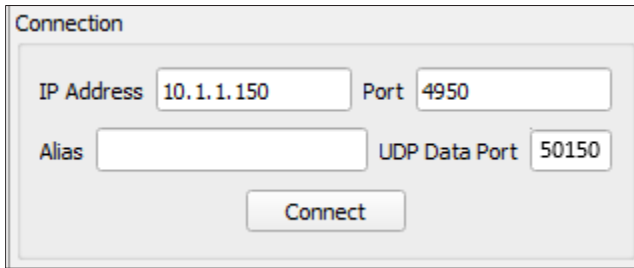

Figure 14: Connection Panel

Connecting to a module

To connect to a module (in the example above, it would be module serial number SSG2-FS-150), the user can type in the module's IP address, port, and UDP port to the corresponding fields in the Connection panel. Once finished, clicking the "Connect" button issues the command to initiate connection to the module at the specified IP address and port. The user can optionally give the module an alias. The alias has no effect on the module performance. It is simply for convenience to identify individual modules when there are multiple modules connected to the Console software.

Each module on a network should have different IP addresses. The "Port" field is the TCP/IP port on which commands can be sent to the module and responses to such commands can be obtained. **This port, by default, is 4950 for all systems.** Systems on the same network can have the same TCP port as long as the IP addresses are different.

The "UDP Data Port" field is the UDP port (of the client computer) on which sample-related data is communicated to the client computer. The count, ratio, divert status, spectrum score, and spectrum of sensed samples can be sent over UDP to the client computer to be displayed on the SpeedSorter CONSOLE.

For each module in a network, a unique UDP Data Port is used. This UDP Data Port is configured on the client computer to match what UDP Data Port each module is set to transmit over. **The UDP Port of any module is 50xxx, where xxx are the last three digits of its serial number.** For example, system SSG2-FS-024 is configured to send data to UDP port 50024 on the client computer.

Repeat this process for all modules (if multiple are being used)

Note: The order in which systems are connected dictates in what order they initially appear top-to-bottom in the module list. This can be re-ordered later by editing the Connection Preset File (described later).

Saving a Connection Preset File

Once all modules are connected, it is convenient to save a Connection Preset File. Click the **Save Connection Preset** button to save the file in its default file location. This file saves the following information for each module for a quicker way to re-connect if the software is ever closed:

1. IP address
2. Port
3. UDP Data port
4. Alias
5. Lane Position
6. System Preset File

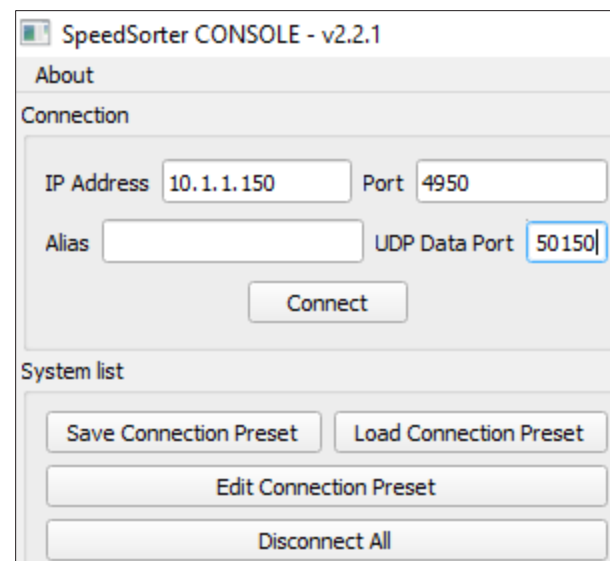

Figure 15: Connection Preset Panel

Loading a Connection Preset File

To load an existing Connection Preset file, select the **Load Connection Preset** button and navigate to the desired file within the file manager window that pops up.

Editing a Connection Preset File

You may edit the currently loaded Connection Preset file by clicking the **Edit Connection Preset** button.

Each field in the table that pops up can be modified. Each row represents a module. In this editor, the Technician can modify the lane position of each system to indicate the order in which the module appears in the System list panel. Modules in a lower-numbered lane will be placed higher in the list.

The columns “Alias” and “System Preset File” are optional. If an “Alias” is not specified, the “Alias” will be empty. If a “System Preset File” is not specified, then no recipe will be applied, and the current settings as stored on the module will be displayed.

A module can also be added or removed from the list using the “Add System” or “Remove System” button. Clicking “Save” will save the new configuration to the connection preset file as specified in the table.

To save the connection preset, click the “Save Connection Preset”. The software will ask the user to select the location to save the connection preset to. Then, the software will save the connection settings for each of the module in the System list, as well as the last system preset loaded for each module.

Note: Do not move or rename a filename or directory containing a recipe file or connection preset file after they have been created. This will cause an error in the SpeedSorter CONSOLE application when it tries to locate it during the load process.

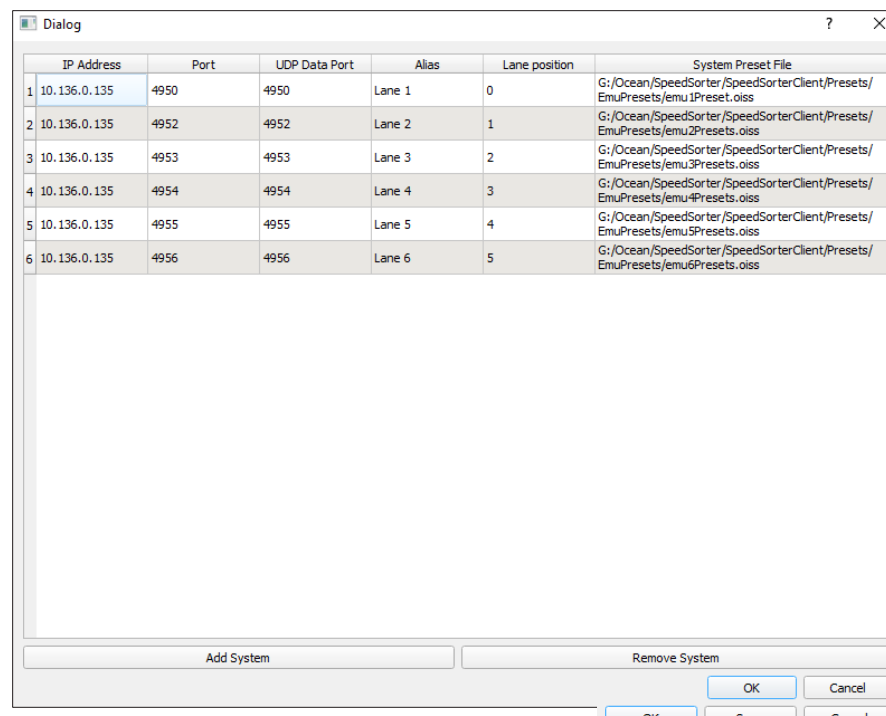

Figure 16: Connection Preset Editor

Controlling an Individual System

To control an individual system, click the **Show** button on the module you wish to control on the left side panel.

Once the desired module is selected you may:

1. Control the behavior of the laser and pilot laser
2. Define the measurement and recipe parameters to be used for sorting
3. Monitor the status, real-time measurement results, and performance history of the system

The SpeedSorter module has two types of lasers:

- The **pilot laser** is a low-powered, eye-safe visible, red laser.
- The **main laser** is a much more powerful, invisible, IR laser which is used to ablate the materials to create plasma for analysis.

The module is designed such that the pilot laser points in the same path as the main laser would. The pilot laser can be used to determine where the main laser will be targeting and for other diagnostic purposes such as alignment.

To start measuring samples, the user needs to click the “Laser On” button. A warning will pop up to indicate that the main laser will be turned on shortly and that no person should be in the path of the main laser. Once the main laser is turned on, the “Main Laser” status bulb on the upper right corner of the panel will light up green.

To turn the main laser off, press the GUI buttons labeled **All Lasers Off** (which turns off all lasers), **Laser Off** (turns off the laser of the presently selected module), or **Emergency Stop** (which turns off all lasers).



Figure 17: Single-System Control Panel

Note: Additionally, the physical E-Stop button on the system can also be pressed in to stop the main laser.

Note: If the main laser is stopped for any reason beside being commanded to do so by the SpeedSorter CONSOLE, an error message will pop up along with some information about the state of the module.

There are several conditions that must be met for the main laser to turn on:

1. The interlock circuit must be in a state that allows the laser to be fired. The external interlock circuit consists of the E-Stop button and a remote-interlock connection which must be shorted to allow the laser to fire. There are also internal safety interlocks within the system. If the whole interlock circuit is in a state that does not allow the laser to fire, the “Interlock” bulb on the upper right corner will light up red. If the interlock circuit allows the laser to fire, the light bulb will not be lit.
2. If the pilot laser is on, the main laser cannot be fired.
3. If the laser chassis temperature is above 40C (104F), the laser cannot be enabled, although it may continue to run if it started while the temperature was below 40C, and may continue up to 50C (122F). This is normal behavior.
4. If the module’s fan is not running, the laser cannot be fired. The module’s fan should be running at all times except for when the ambient temperature, as detected by the module, is below 5C (41F). Under such conditions, the module will try to heat itself to a suitable temperature before the laser can be operated.

Controlling Multiple Systems Simultaneously

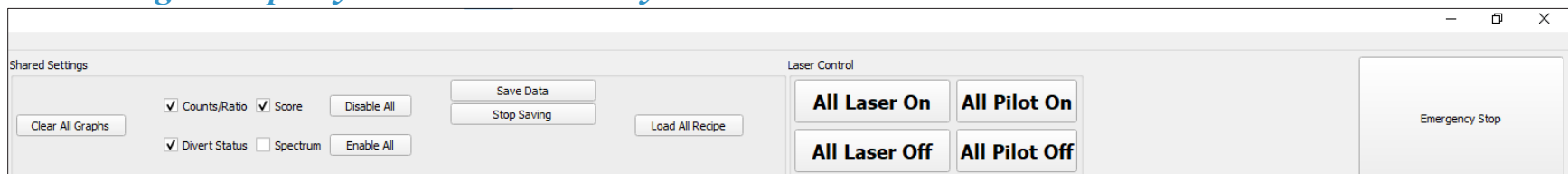

Figure 18: Multi-System Control Panel

To control the laser and graphing behavior of all connected modules, the user can use the buttons in the Multi-System Control Panel. These buttons have the same effect as the buttons in the Single-System Control Panel, except the change will be applied to all modules currently connected to the SpeedSorter CONSOLE software. Additionally, the Emergency Stop button will initiate a “Laser Off” command to all modules.

Creating a Recipe

There are 3 analysis (or recipe) modes available in the SpeedSorter module. In the SpeedSorter CONSOLE, the tab of the current analysis mode will have a yellow-highlighted background when that tab is selected.

Typically, prior knowledge so test or sample parts are needed to empirically determine thresholds of individual elements of interest for a sort. After running a sufficiently representative batch of parts that include parts that are desired from a batch of parts that are not desired, thresholds can be set to separate them from each other.

Single Threshold

In this mode, each element's ratio to the base element is compared against a single value. The comparison can either be greater than (" $>$ ") or less than (" $<$ ").

If an element does not need a comparison, the element should be specified as "Ignore". If the comparison is required for the piece to be diverted, the element should be specified as "Required". In other words, if a condition that is specified as "Required" fails, the piece will be dropped instead of diverted, regardless of other comparisons. If a piece should be diverted as soon as a comparison is met, the comparison should be specified as "Desired". In other words, if a condition that is specified as "Desired" is met, the piece is diverted, regardless of other comparisons. A recipe cannot have a mix of "Desired" and "Required" elements.

Element	Operator	Value	Action
Al	>	0.00	Ignore
Al2	>	0.00	Ignore
Zn	>	0.00	Ignore
Zn2	>	25.00	Required
Cu	>	0.00	Ignore
Mn	>	0.00	Ignore
Mn2	>	0.00	Ignore
Fe	>	10.00	Required
Fe2	>	0.00	Ignore
Si	>	0.00	Ignore
Si2	>	0.00	Ignore
Ni	>	0.00	Ignore
Mg	>	0.00	Ignore
Mg2	>	250.00	Required
Pb	>	0.00	Ignore
Sn	>	0.00	Ignore
Cr	>	0.00	Ignore
Ti	>	0.00	Ignore
Ca	>	0.00	Ignore

Divert Delay: 23ms Divert Duration: 18ms

Divert Active High

Apply Divert Parameters

Figure 19: Single Threshold Recipe Editor

Min-Max

In this mode, each element's ratio to the base element is compared against 2 values. If the ratio falls between the minimum value and the maximum value, the result of the comparison is "true".

If an element does not need a comparison, the element should be specified as "Ignore". If the comparison is required for the piece to be diverted, the element should be specified as "Required". In other words, if a condition that is specified as "Required" fails, the piece will be dropped instead of diverted, regardless of other comparisons. If a piece should be diverted as soon as a comparison is met, the comparison should be specified as "Desired". In other words, if a condition that is specified as "Desired" is met, the piece is diverted, regardless of other comparisons. A recipe cannot have a mix of "Desired" and "Required" elements.

Element	Min	Max	Logic
Al	0.00	100000.00	Ignore
Al2	0.00	100000.00	Ignore
Zn	0.00	100000.00	Ignore
Zn2	0.00	100000.00	Ignore
Cu	0.00	100000.00	Ignore
Mn	0.00	100000.00	Ignore
Mn2	0.00	100000.00	Ignore
Fe	0.00	100000.00	Ignore
Fe2	0.00	100000.00	Ignore
Si	0.00	100000.00	Ignore
Si2	0.00	100000.00	Ignore
Ni	0.00	100000.00	Ignore
Mg	0.00	100000.00	Ignore
Mg2	0.00	100000.00	Ignore
Pb	0.00	100000.00	Ignore
Sn	0.00	100000.00	Ignore
Cr	0.00	100000.00	Ignore
Ti	0.00	100000.00	Ignore
Ca	0.00	100000.00	Ignore

Divert Delay: 23ms Divert Duration: 18ms

Divert Active High

Apply Divert Parameters

Figure 20: Min-Max Recipe Editor

Logic String

In this mode, a Boolean expression can be used to specify the conditions under which a piece should be diverted. If the Boolean expression evaluates to “true”, the piece will be diverted. In this mode, an element’s count or its ratio to any element can be used as a comparator. The other comparator needs to be a number. For example, the logic string “(Fe/Al > 100)” is valid, but “(Fe/Al > Cu/Al)” is not valid.

To combine several elements in the same expression, the following operands may be used:

- “&&”: a logical AND. If both expressions joined by this operand are “true”, then the result is “true”. Otherwise, the result is “false”.
- “||”: a logical OR. If at least one of the expressions joined by this operand is “true”, then the result is “true”. If and only if both are “false”, the result is “false”.

For example, the logic string “(Fe / Al > 1000) || (Cu > 3000)” is true if either the ratio of Fe to Al is greater than 1000, or the count of Cu is greater than 3000.

In this mode, the ratio of any 2 elements in the supported element list can be used. For example, “(Fe/Al > 1000) && (Fe / Mg > 1000)” is a valid logic string.

Each expression needs to be encapsulated in a pair of parentheses, and the parentheses can be used to indicate order-of-operations. For example, the logic string “Fe / Al > 100 && Fe / Mg < 100” is not valid because of missing parentheses, whereas “(Fe / Al > 100) && (Fe / Mg < 100)” is a valid logic string.

Base Element: Al

Logic String: (Cu / Al > 25) && ((Si / Al > 35) || (Mg2 / Al > 250))

Single Threshold

Min Max

Apply

Divert Delay: 23ms

Divert Duration: 18ms

Divert Active High

Apply Divert Parameters

Figure 21: Logic String Recipe Editor

Setting Divert Parameters

Used in conjunction with the recipe are the divert parameters. This is the area where, once a piece is determined to have satisfied all recipe criteria, the system will output a divert pulse.

This pulse has some criteria that can be defined by the user.

Divert Delay: Time (in milliseconds) that elapses from the moment a part is sensed to when a divert pulse is outputted.

Divert Duration: Time (in milliseconds) that the divert pulse is held in the active state for a given piece once the Divert Delay has ended.

Divert Active High: This setting defines if the divert pulse should be Active-High or Active-Low. When Active-High, the divert signal is normally held at 0V, and is temporarily brought to 24V as divert pulses are sent. When Active-Low, the divert signal is normally held at 24V, and is temporarily brought down to 0V as divert pulses are sent.

Apply Divert Parameters: After making changes to these settings, you must click Apply Divert Parameters for them to take effect.

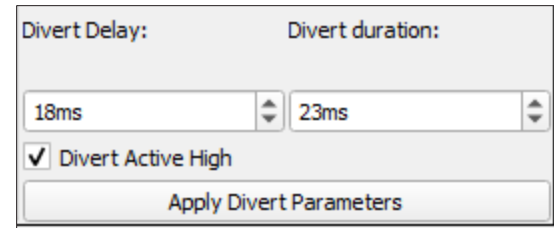

Divert Delay:	Divert duration:
18ms	23ms
<input checked="" type="checkbox"/> Divert Active High	
Apply Divert Parameters	

Figure 22: Divert Settings

Loading a Recipe

Once the SpeedSorter modules are connected, the Technician can select the **Load All Recipe** button, to bring up a window to allow them to select the desired pre-configured sort recipe and apply to all systems.

This will set specific elemental thresholds to actively divert sensed material that satisfies thresholds, or drop sensed material that fails to meet those threshold criteria.

One may also select system-specific recipes by first selecting the "Show" button for a specific SpeedSorter module in the system panel and select the Load Recipe button on the module's main screen.

Note: Recipes use the *.oiss file extension

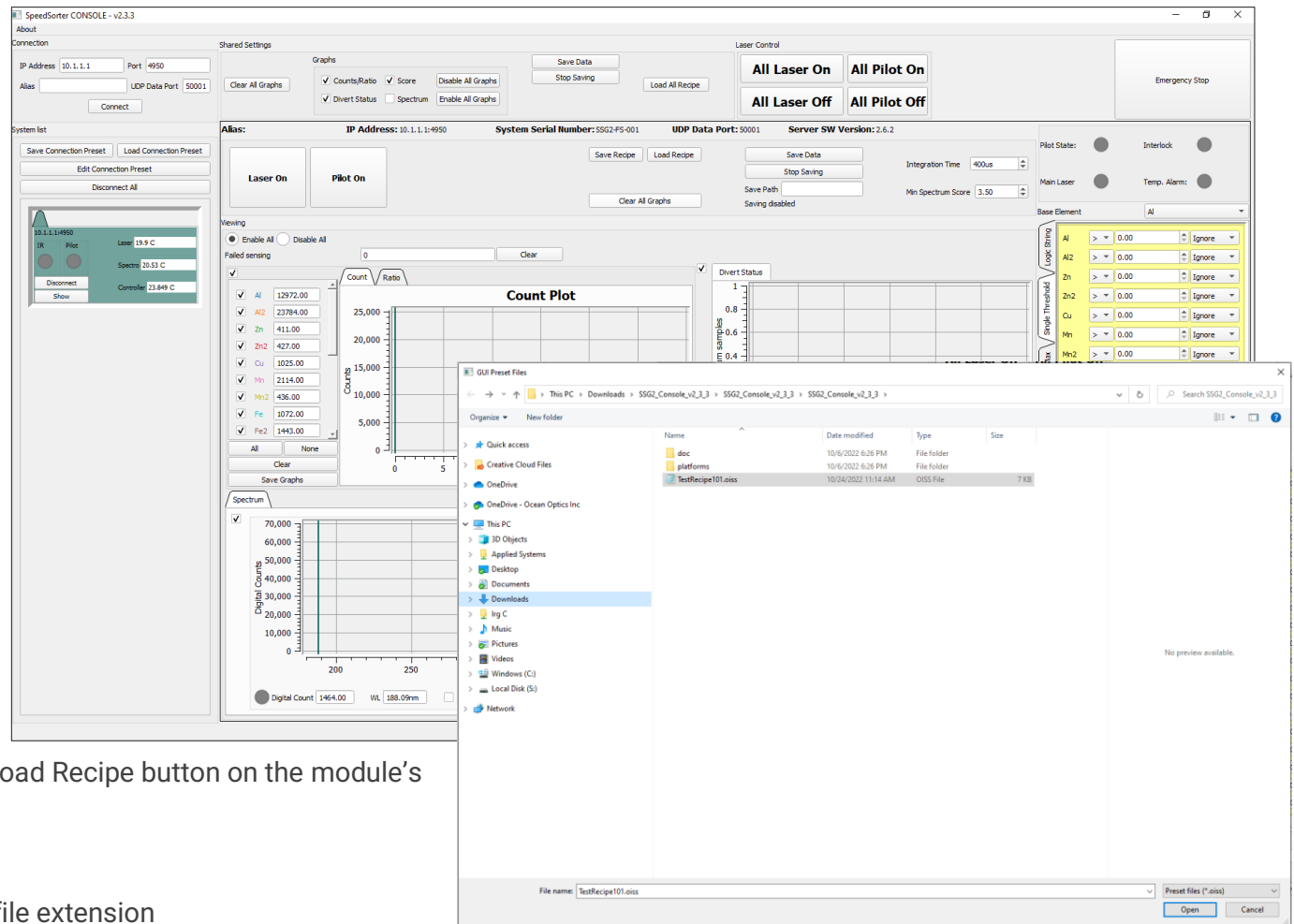

Figure 23: Loading a recipe

Viewing and Understanding Data

The user can configure the module to report the following information:

Counts: Elemental count is defined as the peak height of the elemental peak in terms of digital counts (an arbitrary unit of light intensity). Peak height is computed by subtracting the baseline of the peak region from the highest value in the peak region.

Ratio: Elemental ratio is defined as the ratio between the current element's count and the base element's count, as a percentage (i.e., multiplied by 100). E.g.: The Al count is 100, the Mg count is 200, and Al is the base element. The Mg ratio is $200/100 * 100 = 2 * 100 = 200$. By definition, the elemental ratio of the base element is always 100.

Divert status: Divert status includes how many pieces have been sensed, how many have been determined to pass the divert condition, and how many times the divert has been actuated. If the piece should be diverted, the divert status will be "true". If the piece should not be diverted, the divert status will be "false".

Spectrum score: Spectral score is a metric developed by Ocean to determine the LIBS quality of a spectrum. Spectra with higher number of peaks and more defined/sharper peaks will result in higher spectral score. A dark spectrum would have very low spectral score since there should be minimal peaks, and the peaks are low, not well-defined. Typically values above 3.5 are considered good for most alloys.



Figure 24: Example Data

By default, none of the information is sent back to save on network bandwidth. To enable reporting of each piece of information, a check box near the corresponding graph can be checked. The box next to the count/ratio plot will enable both count/ratio simultaneously. Alternatively, the “Enable All”/“Disable All” radio buttons can be used as shortcuts to apply the change to all graphs.

For the count/ratio graph, individual elements can be toggled to be shown or not shown by clicking the checkbox next to the element’s name. Each element has its own unique color to be displayed on the graph. Additionally, a number box next to the element’s name show the value (either count or ratio, depending on the current graph being shown) of the current sample, as indicated by the vertical black cursor. The black cursor is synced between the count plot, ratio plot, and the spectrum score plot so that the cursor indicates the same sample across multiple graphs.

Each plot can be saved using the “Save” or “Save Graph” button below/next to each plot. The software will prompt the user to select where to save the graph to. The graph will be saved as a .png file.

Saving Data

The SpeedSorter CONSOLE software also allows the user to save data while running the sorting. Saving data is not recommended except for troubleshooting and recipe creation purposes due to the effect on performance from saving data to a file, especially on less-powerful computers. To enable data saving, click “Save Data” button in the individual module control panel. The software will prompt the user to select a folder to save the data to.

Once a folder is selected, any subsequent count, ratio, and spectrum data received from the module will be written out to a corresponding .csv file in the specified folder. Note that the graphing of the data type to be saved needs to be enabled for the data to be saved out. The data file in the specified folder will have the name format: <systemSN>_<count/ratio/spectrum>.csv.

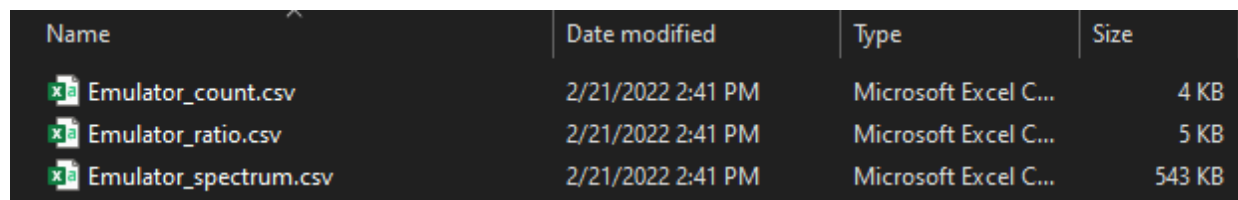

Name	Date modified	Type	Size
Emulator_count.csv	2/21/2022 2:41 PM	Microsoft Excel C...	4 KB
Emulator_ratio.csv	2/21/2022 2:41 PM	Microsoft Excel C...	5 KB
Emulator_spectrum.csv	2/21/2022 2:41 PM	Microsoft Excel C...	543 KB

Figure 25: Example output data files

Once data collection is no longer necessary, the user should click the “Stop Saving” button to stop data logging to avoid unnecessary data from being written out to the files.

Additional Features for Technicians

Spectrum Graph

The Technician also has the ability to see the spectrum measured from the plasma. The spectrum graph, for practical purposes, is only visible as a diagnostic tool. When one is able to view “spiky” peaks across the spectrum, similar to what is shown below, this indicates a proper plasma is being created and is able to be analyzed. All spectra will look different, especially those that differ in their elemental composition from the example below. The important point is that if the peaks look VERY low in amplitude, or are non-existent, this can indicate a part presentation problem (i.e. part speed is wrong, samples are out of focus, or some other system or part handling malfunction is occurring).

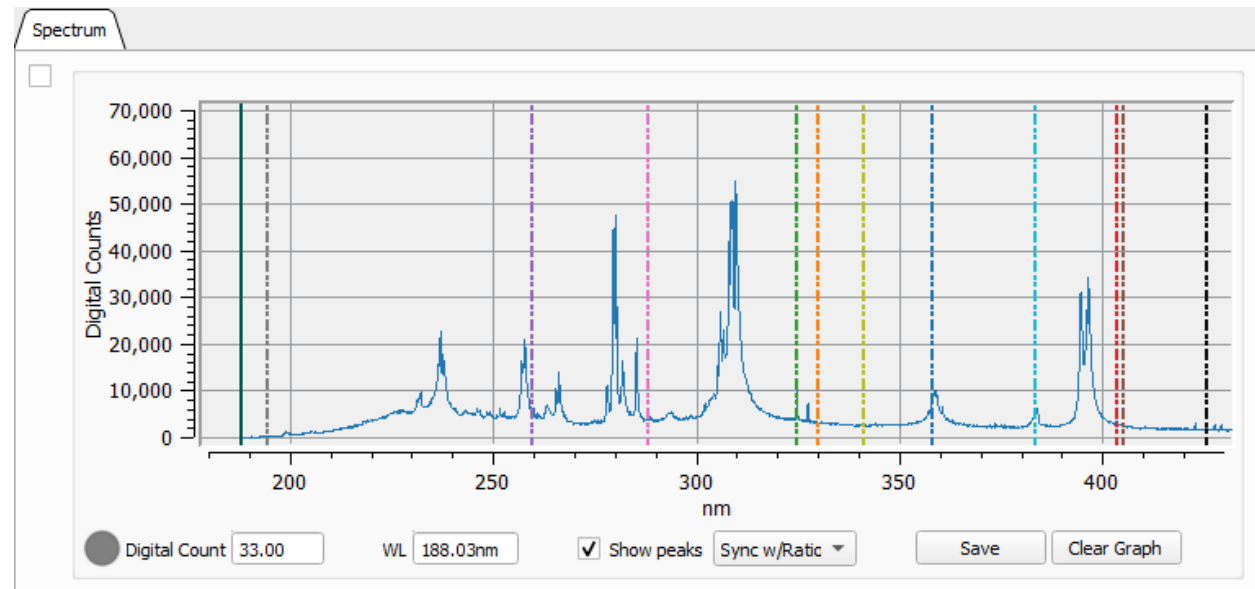

Figure 26: Spectrum graph with elemental lines shown

The peak wavelength for each element can also be displayed by checking the “Show peaks” checkbox. The color of the dashed vertical bar corresponds to the color shown for each element in the count/ratio graph.

The spectrum graph can also be synced with the count, ratio, or spectrum score graph. Using the dropdown box, the graph to sync with can be selected. When synced (i.e. the dropdown box is not “Latest”), the spectrum graph will show the spectrum corresponding to the point selected in the source graph.

Other options on the GUI in this area will display the digital counts and wavelength when the cursor is clicked in the window.

Operator Mode

Upon software startup, the application begins in an “Operator mode” with a restricted feature set.

Note: This mode is intended for use by a machine operator at the sorting site where the system has already been properly set up by an on-site technician or Ocean Applied Systems engineer.

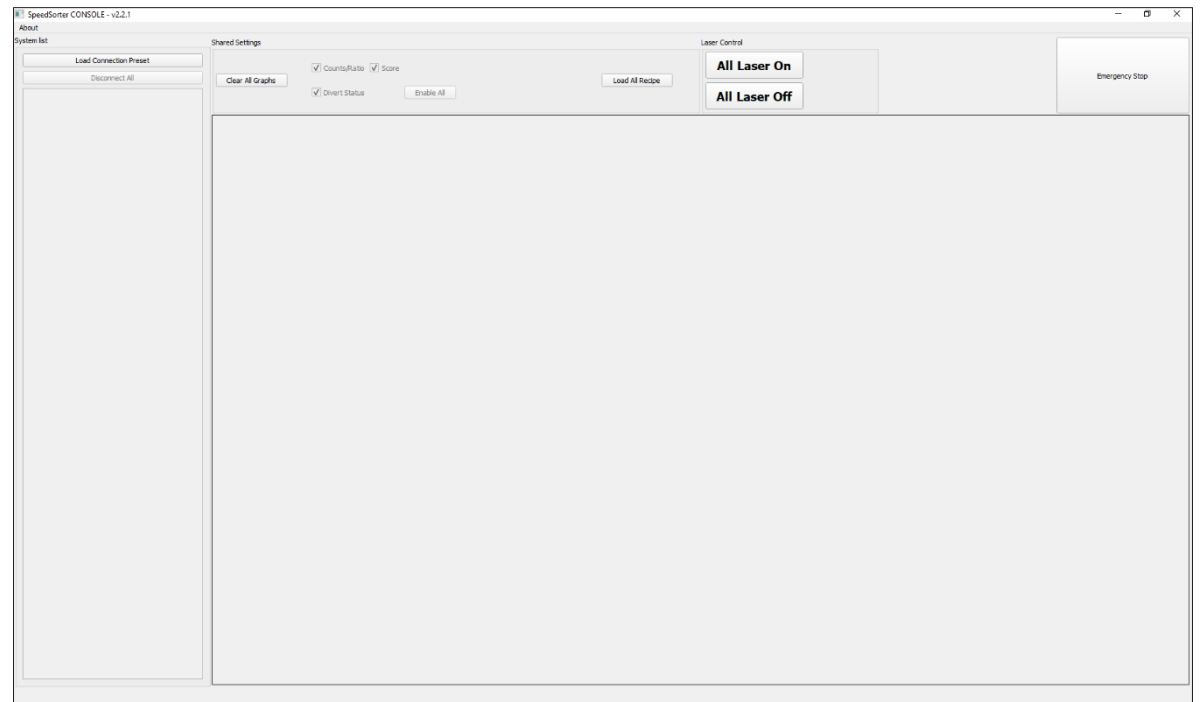

Figure 27: SpeedSorter CONSOLE on startup

Load Connection Preset

To begin, select the “Load Connection Preset” button to bring up a window to access a file containing system configuration settings.

This contains unique information to allow the software to connect to multiple SpeedSorters as a group and apply pre-configured settings and recipes for each system.

Note: This Connection Preset File uses the file extension **.oicp**

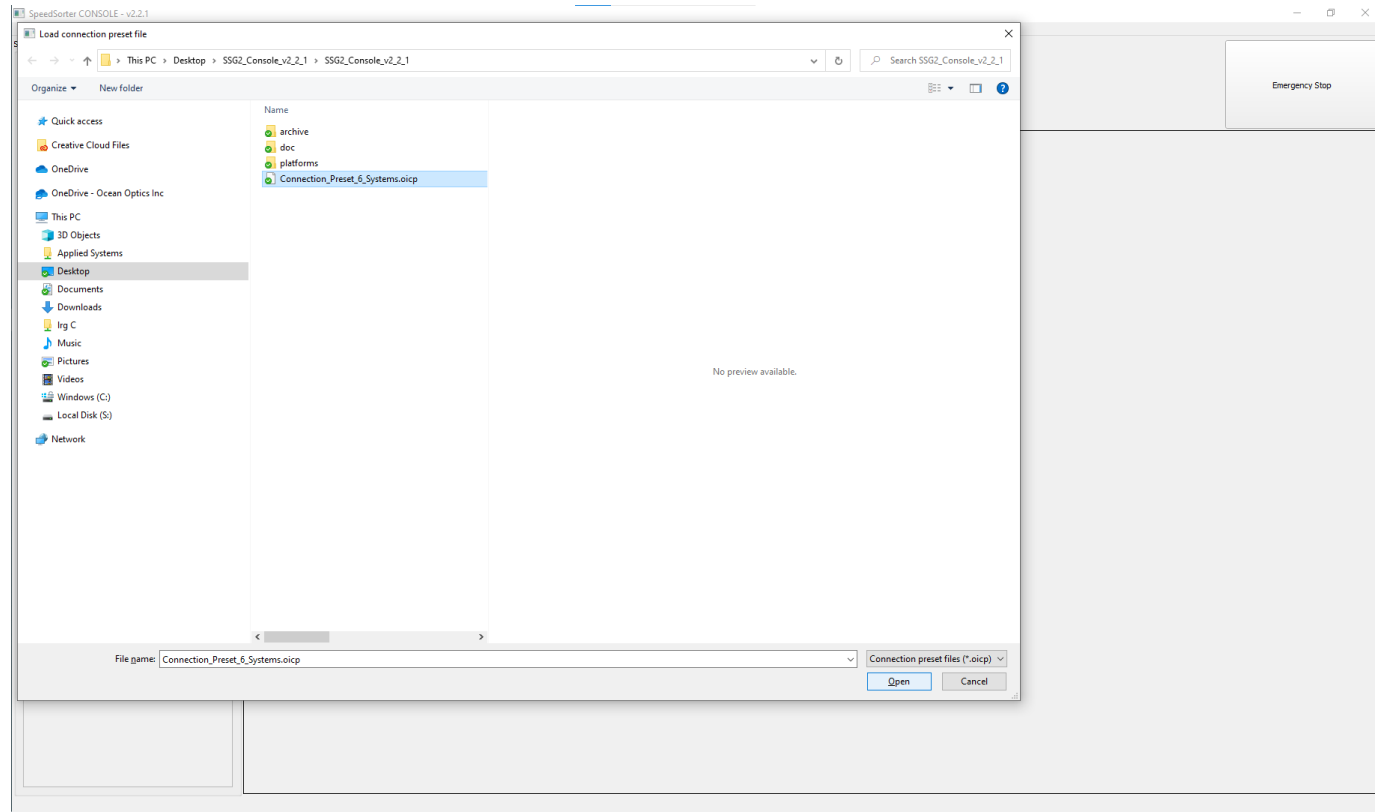

Figure 28: Connection Preset Window

After selecting the pre-configured file and pressing Open, the software will immediately begin connecting to the SpeedSorter system(s) and update the GUI accordingly.

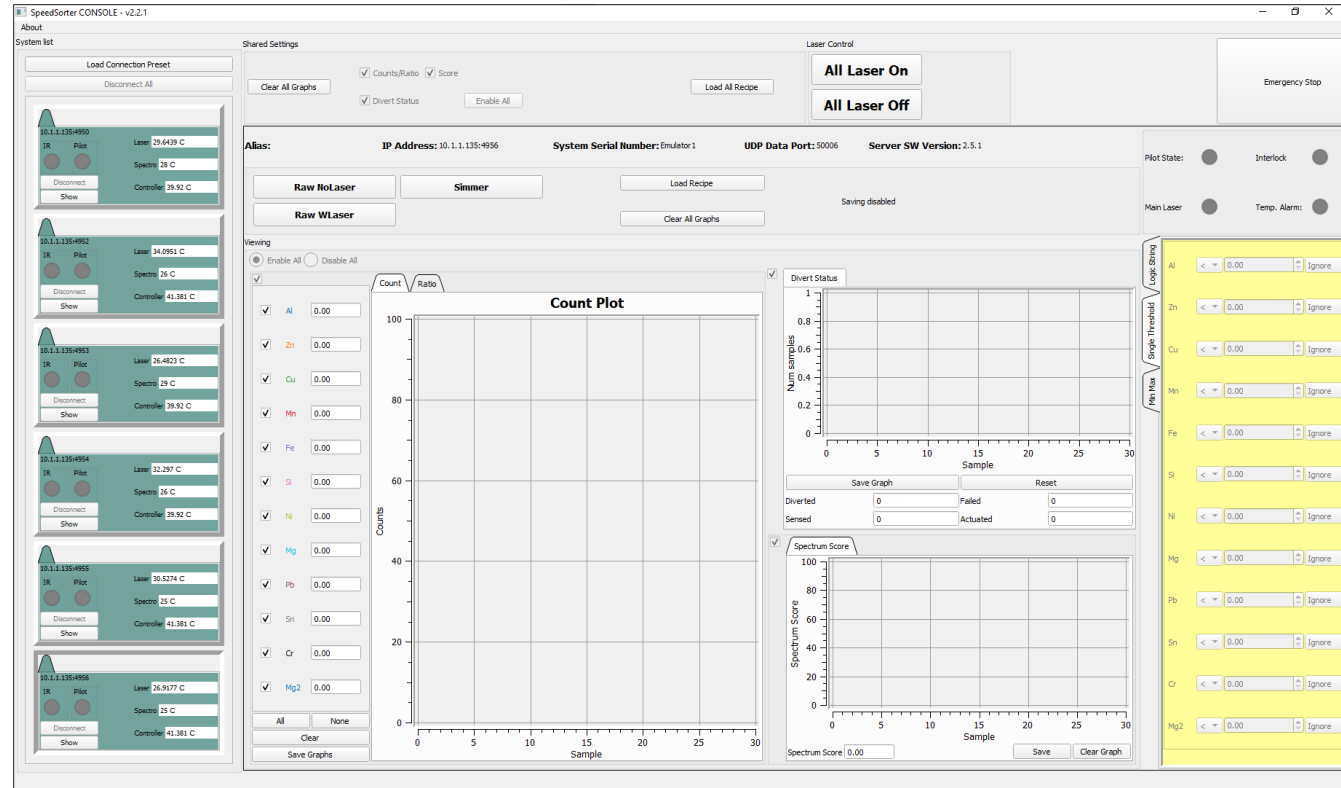

Figure 29: SpeedSorter CONSOLE with modules connected

Running the Lasers/Begin Sorting

Once the recipe is loaded, press the **All Laser On** button. This will activate the lasers of all connected modules and will begin analyzing any sample that passes by the sensors' detection range and make a judgement about whether to divert the part or not.

Warning: Be especially careful when running the system. SpeedSorter uses a high-powered laser that can cut through thin metal and organic matter, such as human tissue, or cause instant and permanent eye damage.

Only operate the system after it has been verified safe and installed correctly by your laser safety officer.

Once the in-feed material has been depleted and fully sorted, you should turn the lasers off by clicking the **All Laser Off** button until the system is needed again.

Contact **Ocean Insight** for any questions, especially dealing with laser safety, so we may advise or direct you to a resource to verify the safety of your installation.



Figure 30: Main screen in Operator Mode

Software API Layer Overview

This document provides a description of the proposed interface between the Ocean Insight Speed Sorter Gen 2 (Speed Sorter) and a computer operated by the user. A single-board computer within the Speed Sorter system will run a TCP/IP server, listening for incoming connections on a specific TCP port. This computer is to be connected to the user's computer via a wired Ethernet link.

TCP/IP has been selected as the communication medium due to its reliability and flexibility. Its twisted-pair differential signaling in the physical layer, combined with checksum and retry mechanisms built into the transport layer, make it a very robust type of connection suitable for use in industrial applications. It also provides a highly configurable routing infrastructure which allows the client software to be run either locally or remotely, and potentially allows multiple clients to connect at once over the same physical link.

Client-Server Architecture

The Speed Sorter system provides a TCP/IP server that responds to requests from client software over the network. This server application, henceforth referred to as the Speed Sorter Server, will listen on TCP port 4950 for incoming connections from clients. Once a client connects in this way, it is able to transmit requests to the server, encoded using the protocol described later in this document.

Each SpeedSorter also reports data about each sample through a UDP connection. The choice to use UDP instead of TCP is due to the required speed and performance of the system. Additionally, data reporting involves spontaneously sending data from the server, which is not consistent with the TCP/IP protocol architecture.

The Speed Sorter Server manages one and only one Speed Sorter instrument, and so all requests are assumed to pertain to that instrument.

Application Protocol

The Speed Sorter communication protocol exists in the application layer (atop TCP/IP over Ethernet). It is a simple binary protocol that is based on the msgpack encoding scheme¹, which is a straightforward system with implementations for every major

¹ See official msgpack specification at <https://github.com/msgpack/msgpack/blob/master/spec.md#str-format-family>

programming language. As mentioned above, every message is either a request (sent from a client to the server), or a response to a request (sent from the server to the originating client).

Every message, both requests and responses, will be formatted as described in Table 1:

Table 1: Message format for the SpeedSorter Gen 2 communication protocol

Byte #	Field	Msgpack Datatype	Description
0 - 4	Greeting	uint16	Always 0x40 0x53 0x53 0x47 0x32 (@SSG2)
5 - 8	Message Length	uint32 (big endian)	Length in bytes of entire message, excluding Greeting and Message Length fields
9 - 11	Opcode	uint16 (big endian)	Describes operation to be performed
11 - N	Body	multiple sequential elements (opcode dependent)	Body of message, containing data payload as a sequence of objects, whose types are defined by the specific opcode and request/response bit for this message
N+1 - N+5	Footer	uint16	Always 0x4C 0x49 0x42 0x53 0x40 (LIBS@)

Message Types

Request from Client

System Information

Opcode	Argument(s)	Description
0x0000	None	Keep alive message
0x0001	None	Request system information (manufacturer info, system model, software version, sensor serial number, hardware configuration)
0x0002	None	Request time since system epoch (in ms)
0x0003	None	Get raw wavelengths of spectrometer
0x0004	None	Get wavelength coefficients of spectrometer

System Environmental Condition

Opcode	Argument(s)	Description
0x0100	None	Get system thermal information

Data Acquisition

Opcode	Argument type	Description
0x0200	None	Query the list of supported elements and their ID
0x0201	Array of double	Set element peak wavelengths (nm)
0x0202	None	Get element peak wavelengths (nm)

0x0203	3 arrays: <ul style="list-style-type: none"> - Threshold (double) - ">" or "<" (string) - String ("Required", "Desired", "Ignored") 	Set parameters for Single Threshold mode
0x0204	None	Get parameters for Single Threshold mode
0x0205	String	Set current logic string
0x0206	None	Get current logic string
0x0207	3 arrays: <ul style="list-style-type: none"> - Minimum threshold (double) - Maximum threshold (double) - String ("Required", "Desired", "Ignored") 	Set element thresholds for Min Max mode
0x0208	None	Get element thresholds for Min Max mode
0x0209	String (either "Single Threshold", "Min Max", "Logic String")	Set current analysis mode (Single Threshold, Min Max, Logic String)
0x020A	None	Get current analysis mode
0x020B	Double	Set minimum spectral score
0x020C	None	Get minimum spectral score
0x020D	Array of bools: <ul style="list-style-type: none"> - Report counts - Report ratios - Report divert status - Report spectral score - Report spectrum 	Set data report mode

0x020E	None	Get data report mode
0x020F	Unsigned integer	Set spectrometer integration time (microseconds)
0x0210	None	Get spectrometer integration time (microseconds)
0x0211	None	Get base element name
0x0212	String	Set base element name. The base element needs to be in the element list supported by the system.
0x0213	Boolean	Set Result Code report mode
0x0214	None	Get Result Code report mode

Laser Control

Opcode	Argument type	Description
0x0300	Boolean (true = on)	Set main laser state
0x0301	None	Get main laser state
0x0302	Boolean (true = on)	Set pilot laser state
0x0303	None	Get pilot laser state
0x0304	None	Get laser alarms
0x0305	None	Get laser status bits

Divert Control

Opcode	Argument type	Description
0x0400	<ul style="list-style-type: none">- Divert delay (ms) (uint32)- Divert duration (ms) (uint32)- Active high or low (Boolean)	Set divert parameters
0x0401	None	Get divert parameters

Response from server

System Information

Opcode	Argument(s)	Description
0x0000	None	Acknowledge that the system has received the keep alive
0x0001	Array of 5 strings: <ul style="list-style-type: none">- Manufacturer info- System model- Software version- Serial number- HW configuration	Current system information
0x0002	Uint64	Time since system epoch (ms)
0x0003	Array of 2048 doubles: <ul style="list-style-type: none">- Wavelengths	Raw wavelengths of spectrometers
0x0004	Array of 5 doubles: <ul style="list-style-type: none">- Coefficients from 0th to 5th order	Wavelength coefficients of the spectrometer

System Environmental Condition

Opcode	Argument(s)	Description
0x0100	Array of 4 doubles: <ul style="list-style-type: none">- Laser temperature- Spectrometer temperature- Housing temperature- Computer temperature	Current system thermal information

Data Acquisition

Opcode	Argument type	Description
0x0200	Array of N element IDs	List of supported elements and their ID
0x0201	Array of doubles corresponding to each element's peak wavelengths (ordered by element ID)	Set element peak wavelengths (nm)
0x0202	Array of doubles corresponding to each element's peak wavelengths (ordered by element ID)	Get element peak wavelengths (nm)
0x0203	3 arrays (ordered by element ID): <ul style="list-style-type: none"> - Threshold (double) - ">" or "<" (string) - String ("Required", "Desired", "Ignored") 	Current Single Threshold mode parameters
0x0204	3 arrays (ordered by element ID): <ul style="list-style-type: none"> - Threshold (double) - ">" or "<" (string) - String ("Required", "Desired", "Ignored") 	Current Single Threshold mode parameters
0x0205	String	Current logic string after changes have been applied
0x0206	None	Current logic string
0x0207	3 arrays (ordered by element ID): <ul style="list-style-type: none"> - Minimum threshold (double) - Maximum threshold (double) - String ("Required", "Desired", "Ignored") 	Current Min Max mode parameters after changes have been applied

0x0208	3 arrays (ordered by element ID): <ul style="list-style-type: none"> - Minimum threshold (double) - Maximum threshold (double) - String ("Required", "Desired", "Ignored") 	Get element thresholds for Min Max mode
0x0209	String (either "Single Threshold", "Min Max", "Logic String")	Set current analysis mode (Single Threshold, Min Max, Logic String)
0x020A	String (either "Single Threshold", "Min Max", "Logic String")	Get current analysis mode
0x020B	Double	Current minimum spectral score
0x020C	Double	Current minimum spectral score
0x020D	Array of Boolean (true = data report enabled): <ul style="list-style-type: none"> - Elemental counts - Elemental ratios (vs. base element) - Divert status - Spectral score - Spectrum 	Current data report modes
0x020E	Array of Boolean (true = data report enabled): <ul style="list-style-type: none"> - Elemental counts - Elemental ratios (vs. base element) - Divert status - Spectral score - Spectrum 	Current data report modes
0x020F	Unsigned integer	Current integration time (microseconds)

0x0210	Unsigned integer	Current integration time (microseconds)
0x0211	String	Get the base element name
0x0212	None	Set the base element name
0x0213	None	Set Result Code report mode
0x0214	Boolean	Get Result Code report mode

Laser Control

Opcode	Argument type	Description
0x0300	Boolean (true = on)	Main laser state
0x0301	Boolean (true = on)	Main laser state
0x0302	Boolean (true = on)	Pilot laser state
0x0303	Boolean (true = on)	Pilot laser state
0x0304	None	Get laser alarms
0x0305	None	Get laser status bits

Divert control

Opcode	Argument type	Description
0x0400	A tuple of the following: <ul style="list-style-type: none">- Divert delay, in ms (uint32)- Divert duration, in ms (uint32)- Is divert active high? (Boolean)	Divert system parameters
0x0401	A tuple of the following: <ul style="list-style-type: none">- Divert delay, in ms (uint32)- Divert duration, in ms (uint32)- Is divert active high? (Boolean)	Divert system parameters

Other

Opcode	Argument type	Description
0xFF00	String	Error message

UDP Data Reporting Protocol

Each system reports sample data via a UDP connection to a specified port on the client computer. This port may vary from system-to-system and can be modified in the server configuration file.

Each UDP packet sent will have the format described in Table 2:

Table 2: Message format for the SpeedSorter Gen2 UDP data reporting

Byte #	Field	Msgpack Datatype	Description
0	UDP Packet Version	uint8	Version number for the UDP packet format to ensure compatibility
1	Opcode/Message Type	uint8	Describe the type of information contained in this packet
2-5	Body length	uint32	The length of the response body, in bytes.
6-N	Body	multiple sequential elements (opcode dependent)	Body of message, containing data payload as a sequence of objects, whose types are defined by the specific opcode and request/response bit for this message

The body of each message contains data serialized using msgpack, similar to the body of the TCP messages.

The details for each message type is included below:

Opcode	Argument(s)	Description
0x00	A tuple of the following: <ul style="list-style-type: none"> - UUID for measurement (uint64_t) - Piece start time, in us since UNIX epoch (uint64_t) 	Elemental counts for the last sample sensed. The UUID can be used to match the counts with other information (e.g. ratios, spectrum, etc...).

	<ul style="list-style-type: none"> - Piece end time, in us since UNIX epoch (uint64_t) - Elemental counts (array of uint16_t) 	
0x01	<p>A tuple of the following:</p> <ul style="list-style-type: none"> - UUID for measurement (uint64_t) - Piece start time, in us since UNIX epoch (uint64_t) - Piece end time, in us since UNIX epoch (uint64_t) - Elemental ratios (array of doubles) 	Elemental ratios for the last sample sensed. The UUID can be used to match the counts with other information (e.g. ratios, spectrum, etc...).
0x02	<p>A tuple of the following:</p> <ul style="list-style-type: none"> - UUID for measurement (uint64_t) - Piece start time, in us since UNIX epoch (uint64_t) - Piece end time, in us since UNIX epoch (uint64_t) - Divert decision (boolean, true = diverted) 	The divert decision for the last sample sensed. True = the piece should be diverted. The UUID can be used to match the counts with other information (e.g. ratios, spectrum, etc...).
0x03	<p>A tuple of the following:</p> <ul style="list-style-type: none"> - UUID for measurement (uint64_t) - Piece start time, in us since UNIX epoch (uint64_t) - Piece end time, in us since UNIX epoch (uint64_t) - Spectral score (double) 	The spectral score for the last sample sensed. High score = more LIBS-like. The UUID can be used to match the counts with other information (e.g. ratios, spectrum, etc...).

0x04	A tuple of the following: <ul style="list-style-type: none"> - UUID for measurement (uint64_t) - Piece start time, in us since UNIX epoch (uint64_t) - Piece end time, in us since UNIX epoch (uint64_t) - Spectrum (array of 2048) 	Spectrum of the last sample. Each index in the array correspond to the intensity at that pixel. The wavelength can be queried via TCP protocol. The UUID can be used to match the counts with other information (e.g. ratios, spectrum, etc...).
0x05	None	This message is a UDP heartbeat message. It is sent out so the client can verify that the UDP port it is listening to is the correct one. The message is sent every 1 second.
0x06	A tuple of the following: <ul style="list-style-type: none"> - UUID for measurement (uint64_t) - Piece start time, in us since UNIX epoch (uint64_t) - Piece end time, in us since UNIX epoch (uint64_t) - Result code (int64_t) 	Result code of the last sample. See Result Code for the list of result codes and their meanings.

Definitions of Terms

Keep Alive message

The system requires a Keep Alive message to be sent every 5 seconds when the laser is firing. The purpose of this Keep Alive message is to ensure the connection between the client and the system is alive for safety reasons. If the system does not receive the message within this period, the laser will be turned off with the assumption that the client has disconnected. The system will also treat any incoming messages over TCP as a Keep Alive message.

Analysis modes

Single Threshold

In this analysis mode, each element's ratio is compared to a specified value. The comparison can be either greater (>) or less than (<) the specified value. If the element should not be considered, the comparison should be marked as "Ignored". If the sample should be diverted if the comparison is True, the comparison should be marked as "Desired". If the sample should be NOT be diverted if the comparison is False, the comparison should be marked as "Required".

Min - Max

In this analysis mode, each element's ratio is compared to a minimum value and a maximum value. The comparison is considered True if the ratio falls between the minimum value and maximum value. If the element should not be considered, the comparison should be marked as "Ignored". If the sample should be diverted if the comparison is True, the comparison should be marked as "Desired". If the sample should be NOT be diverted if the comparison is False, the comparison should be marked as "Required".

Logic String

The user can specify a logic string which can be used to specify the condition for a piece to be diverted. If the logic string evaluates to true, the piece will be diverted. The logic string is a Boolean expression with each individual terms of the expression being a comparison between a count/ratio and a number. Each comparison should be wrapped inside a pair of parentheses. Additionally, the user can use Boolean operations ! (not), && (and), and || (or) to form a more complex logic string. The order of operations is: parentheses, !, &&, ||. Example:

```
((Mg/Al > 200) && ! (Zn/Al < 300)) || (Cu > 10000)
```

The above logic string will result in a divert if the sample produces the following conditions:

- The Cu count is greater than 10000
- The Mg to Al ratio is greater than 200 AND the Zn to Al ratio is NOT less than 300.

If neither of the above conditions are met, the piece will NOT be diverted.

Divert parameters

The system generates a divert signal if a sample should be diverted. This timing of this divert signal can be configured with the following parameters:

Divert delay (ms): The time between when the last spectrum of the sample is sensed and when the divert signal should be generated.

Divert duration (ms): The duration for which the divert signal will be active for the current sample.

The divert signal can be configured to be active high or active low using the Boolean variable in message 0x0400.

Result Code

When a piece is analyzed, a result code is associated with the piece to indicate if the piece was successfully analyzed, or some problem occurred. The result codes are explained in the table below.

Table 3: Result Code

Code	Description
0	The piece was successfully detected and analyzed. A divert decision was made on the piece.
1	The piece was detected, but none of the spectra obtained from the piece was suitable for LIBS analysis. The cause could be due to poor focus.

Questions?

Chat with us at [OceanInsight.com](https://www.oceaninsight.com).

info@oceaninsight.com • **US** +1 727-733-2447

EUROPE +31 26-3190500 • **ASIA** +86 21-6295-6600

Unlock the Unknown

Ocean Insight exists to end guessing. We equip humanity with technology and data to make precisely informed decisions providing transformational clarity for human advancement in health, safety, and the environment.